

Motor: 1 x Internal Motor

Lighting: Tunable White LED

Motor & Light Controls: Tactile Pushbutton (Remote Control Compatible)

Duct: 1 x 150mm  $\varnothing$  Top Outlet

Soffit Opening - 1080mm x 266mm

Soffit Thickness - 15mm Minimum upto 22mm Maximum

The extractor is fixed in place by 4 adjustable spring toggles.

Supplementary support of the unit is provided by 2 x sprung safety clips at opposite corners of the unit.

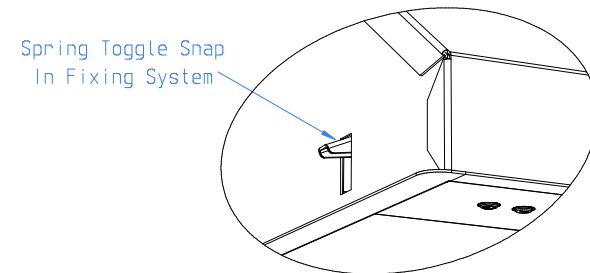

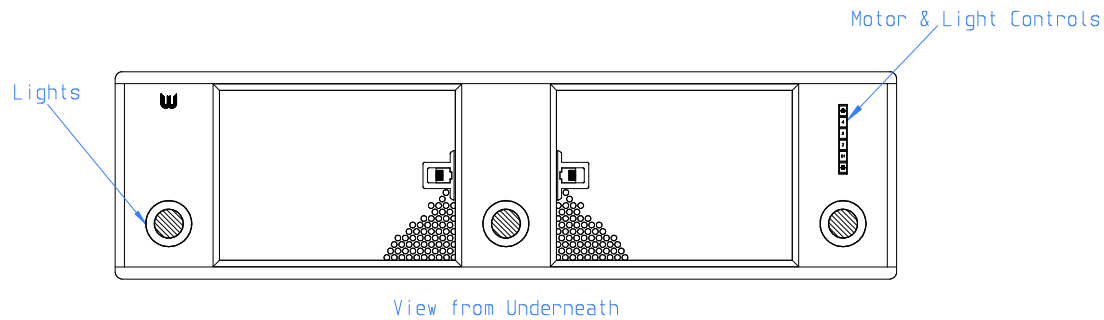
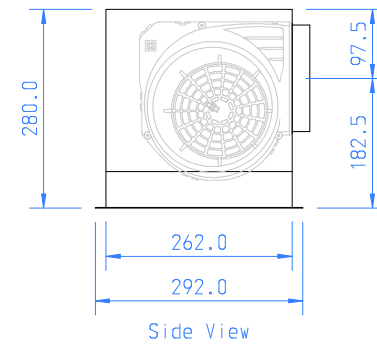
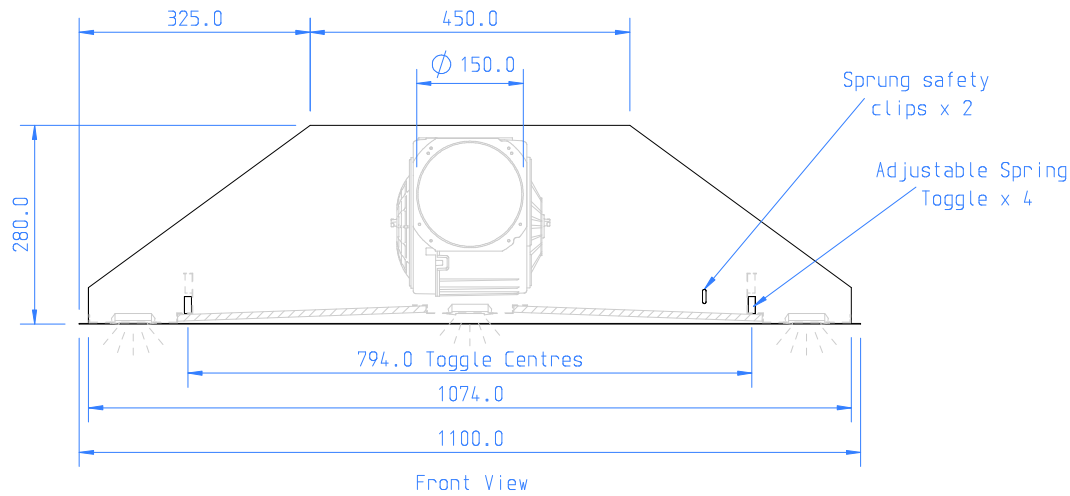
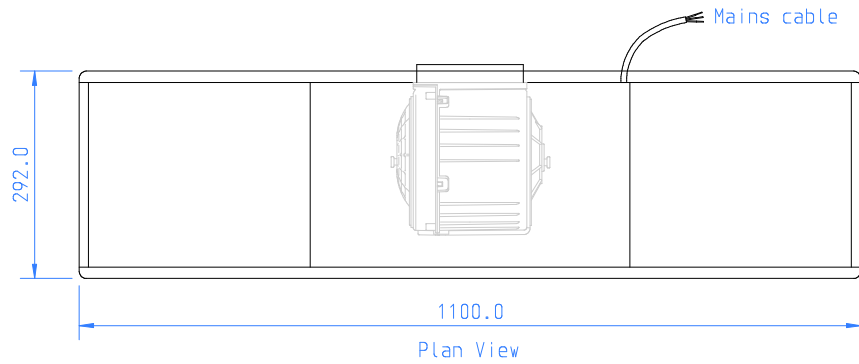

Motor: 1 x Internal Motor

Lighting: Tunable White LED

Motor & Light Controls: Tactile Pushbutton (Remote Control Compatible)

Duct: 1 x 150mm  $\varnothing$  Rear Outlet

Soffit Opening - 1080mm x 266mm

Soffit Thickness - 15mm Minimum upto 22mm Maximum

The extractor is fixed in place by 4 adjustable spring toggles.

Supplementary support of the unit is provided by 2 x sprung safety clips at opposite corners of the unit.

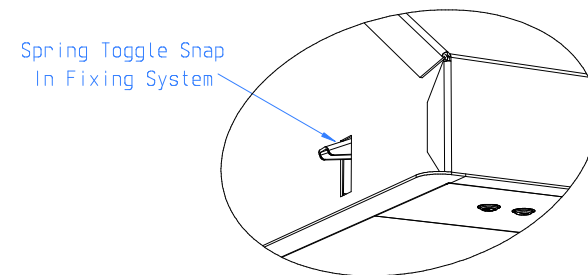

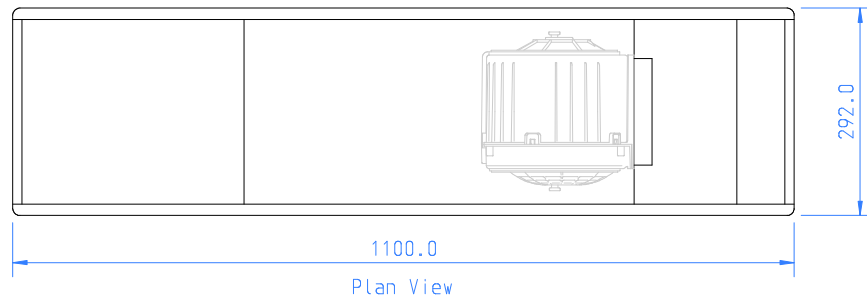

Motor: 1 x Internal Motor

Lighting: Tunable White LED

Motor & Light Controls: Tactile Pushbutton (Remote Control Compatible)

Duct: 1 x 150mm  $\varnothing$  Right Outlet

Soffit Opening - 1080mm x 266mm

Soffit Thickness - 15mm Minimum upto 22mm Maximum

The extractor is fixed in place by 4 adjustable spring toggles.

Supplementary support of the unit is provided by 2 x sprung safety clips at opposite corners of the unit.

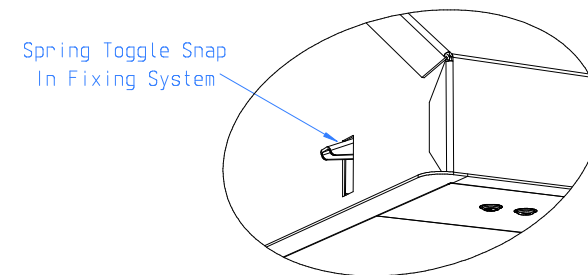
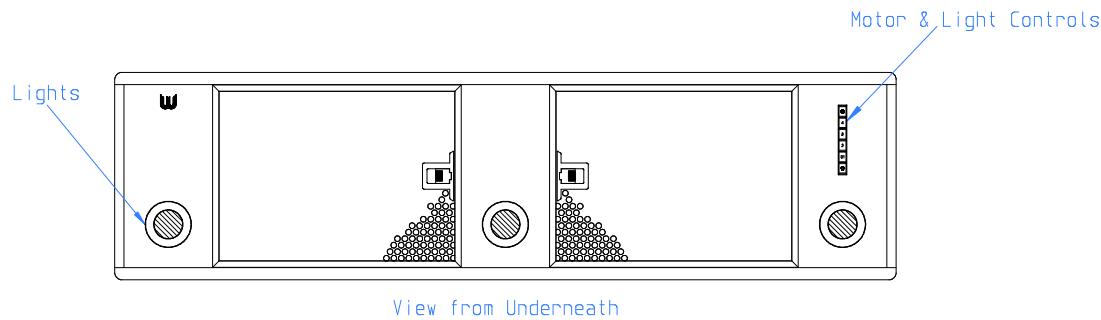
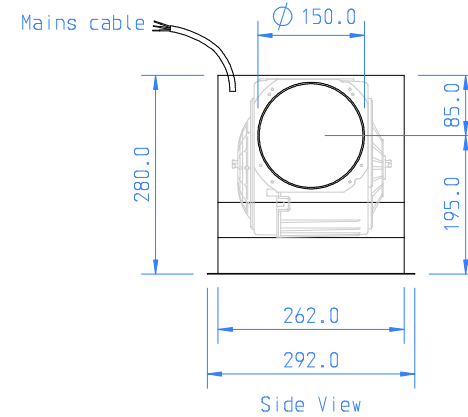
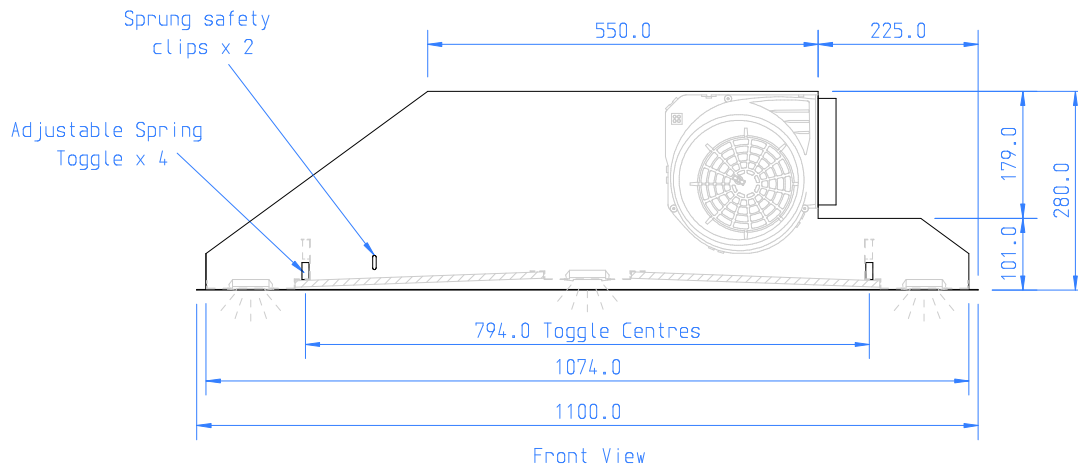

Client: Westin  
 Drawn by: Daniel Bradley  
 Title: WSW - PRIME 1100 - RHS - SS GA V1 20220208

Ref: WSW - PRIME 1100 - RHS - SS

Approved by:

Date:

Scale: 1:10 A4  
 Units: mm  
 Date: 08-02-22

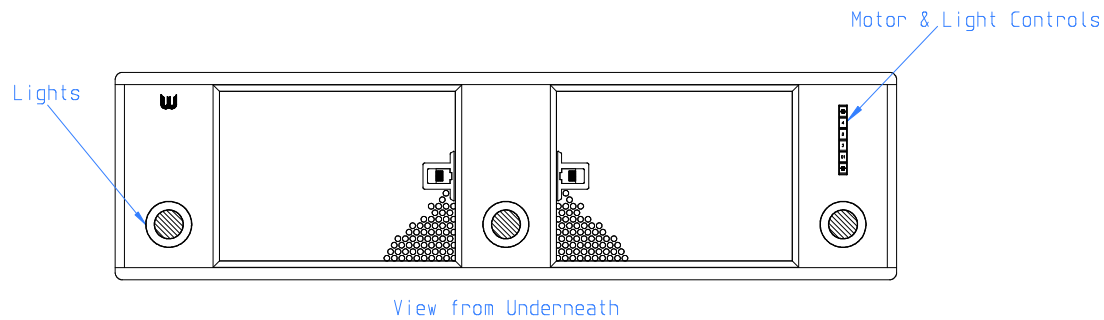
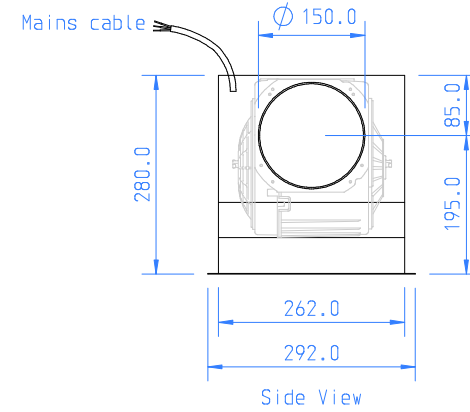
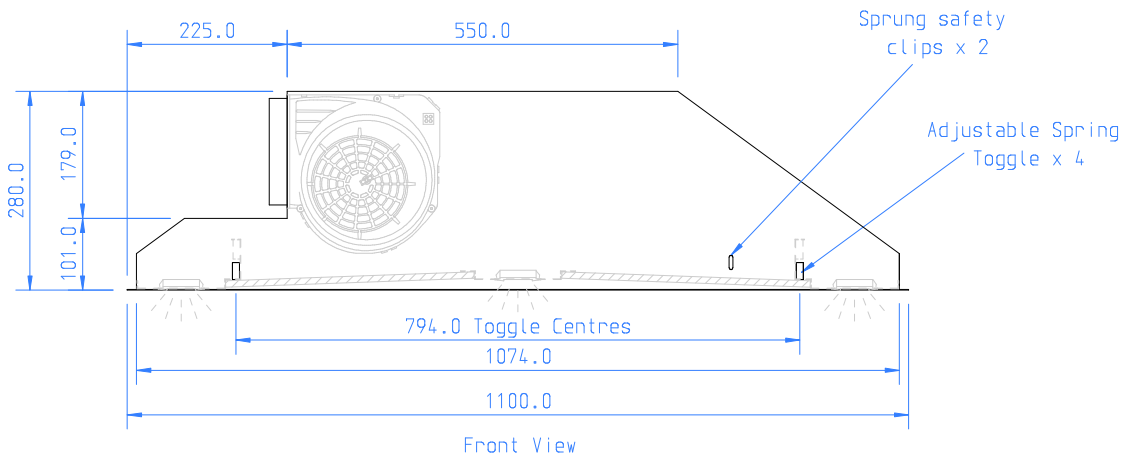
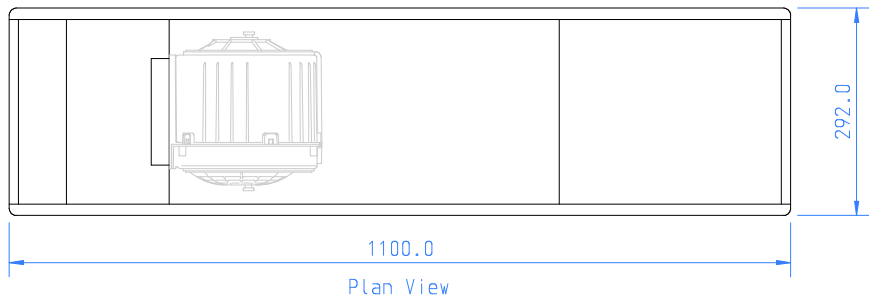

Motor: 1 x Internal Motor  
 Lighting: Tunable White LED  
 Motor & Light Controls: Tactile Pushbutton (Remote Control Compatible)  
 Duct: 1 x 150mm  $\varnothing$  Left Outlet  
 Soffit Opening - 1080mm x 266mm  
 Soffit Thickness - 15mm Minimum upto 22mm Maximum  
 The extractor is fixed in place by 4 adjustable spring toggles.  
 Supplementary support of the unit is provided by 2 x sprung safety clips at opposite corners of the unit.

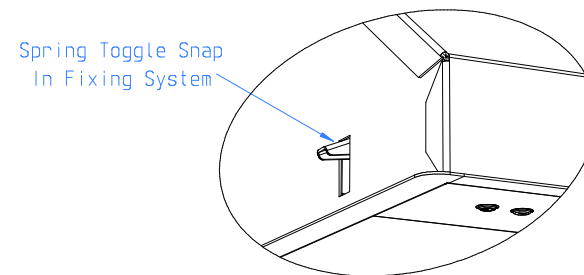

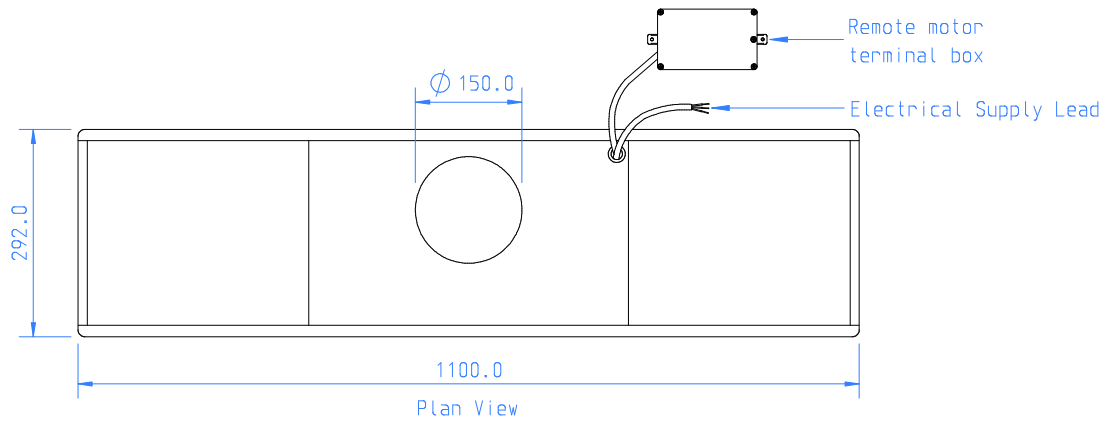

Motor: 1 x SEM Remote Motor - Separate Item

Lighting: Tunable White LED

Motor & Light Controls: Tactile Pushbutton (Remote Control Compatible)

Duct: 1 x 150mm  $\varnothing$  Top Outlet

Soffit Opening - 1080mm x 266mm

Soffit Thickness - 15mm Minimum upto 22mm Maximum

The extractor is fixed in place by 4 adjustable spring toggles.

Supplementary support of the unit is provided by 2 x sprung safety clips at opposite corners of the unit.

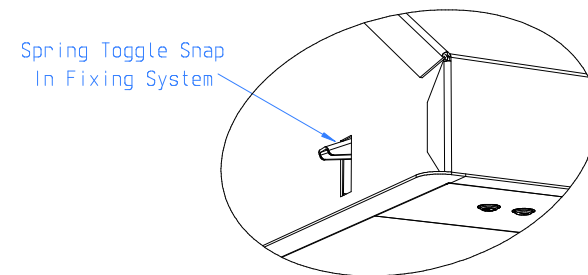
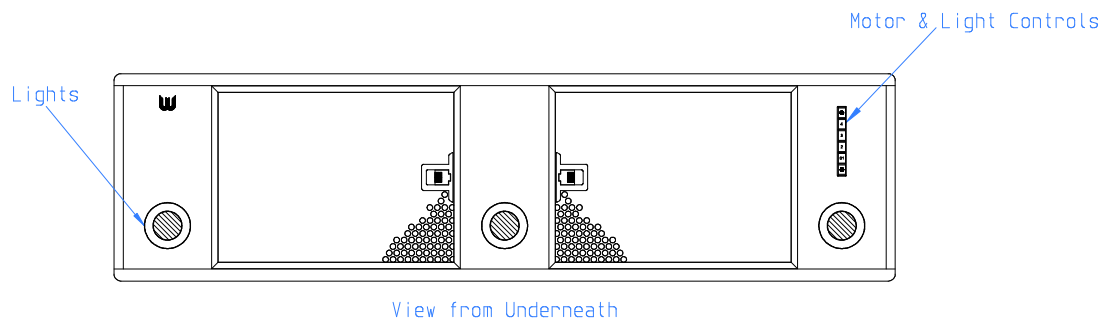
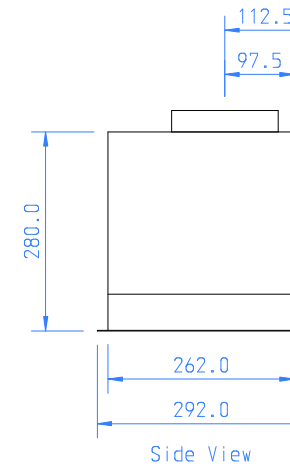
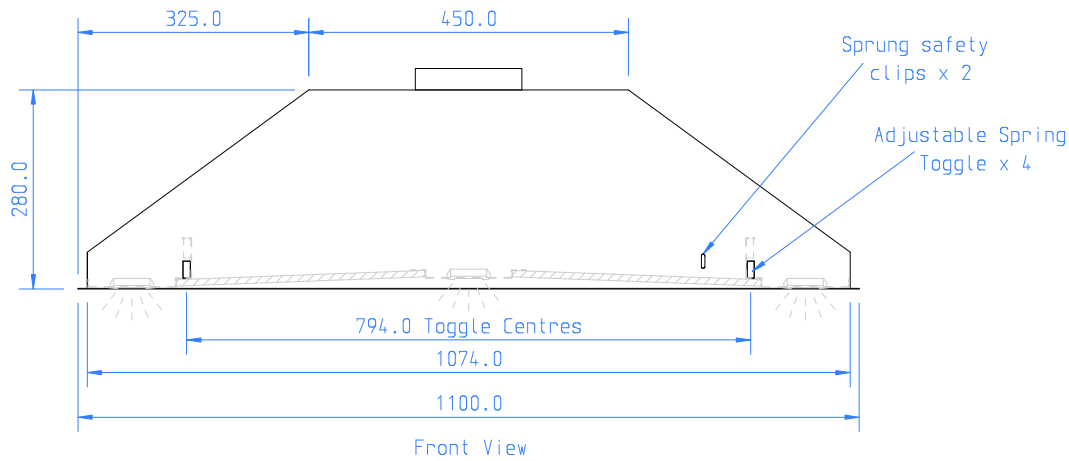

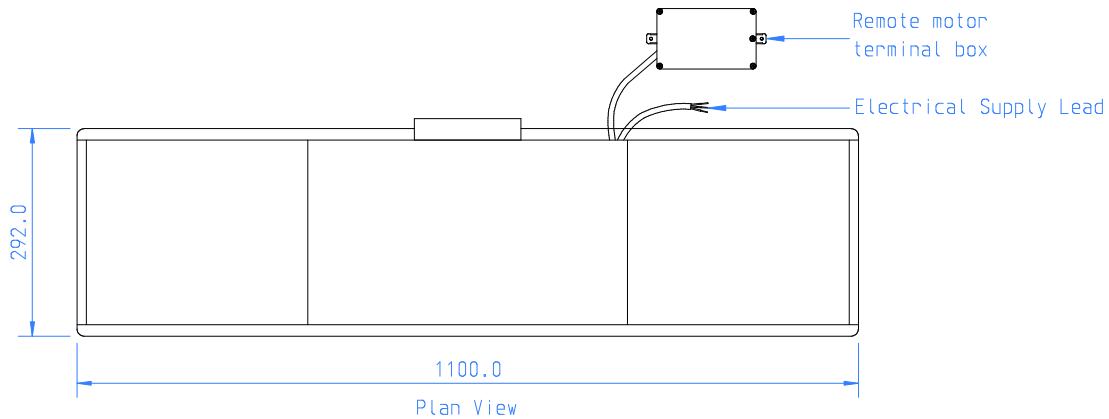

Motor: 1 x SEM Remote Motor - Separate Item  
 Lighting: Tunable White LED  
 Motor & Light Controls: Tactile Pushbutton (Remote Control Compatible)  
 Duct: 1 x 150mm  $\varnothing$  Rear Outlet  
 Soffit Opening - 1080mm x 266mm  
 Soffit Thickness - 15mm Minimum upto 22mm Maximum  
 The extractor is fixed in place by 4 adjustable spring toggles.

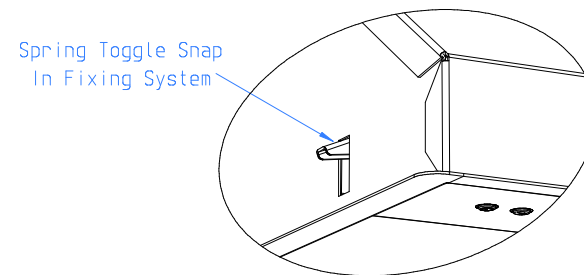
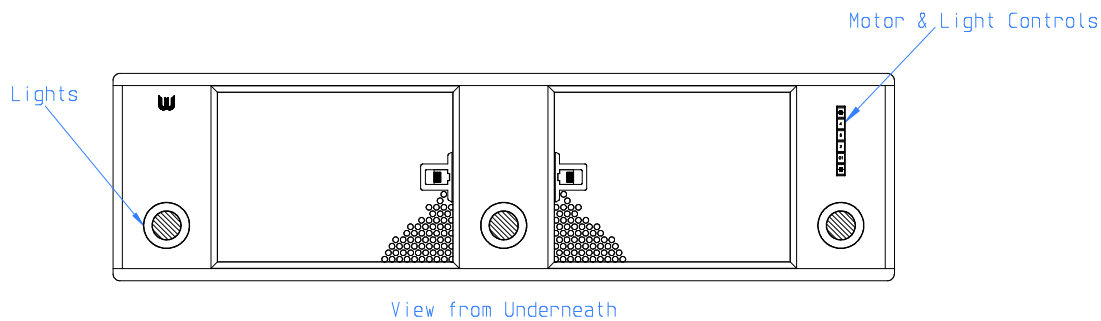
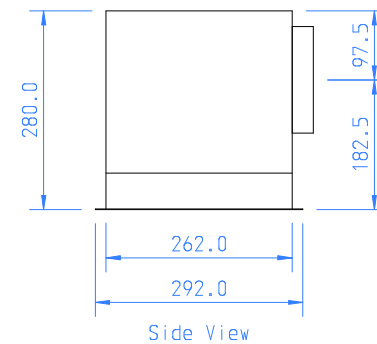
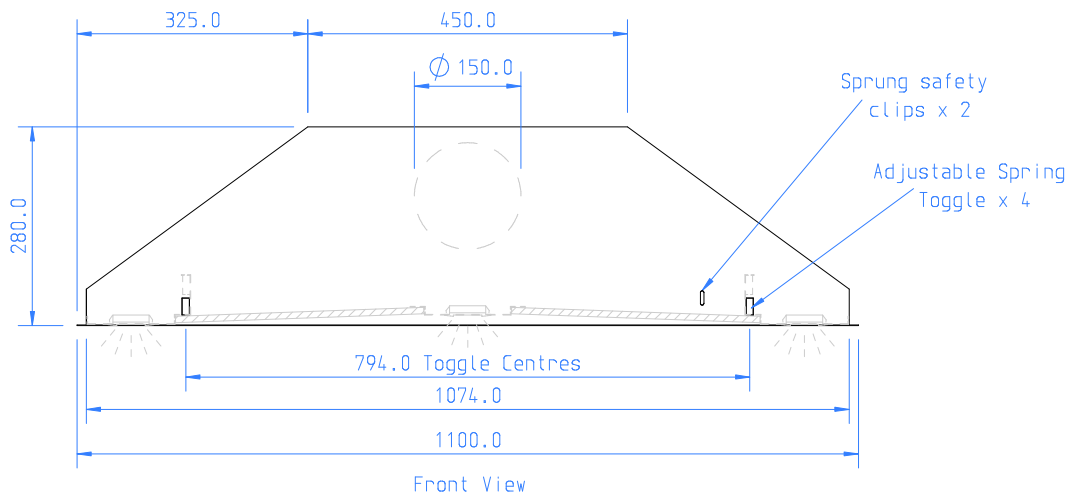

Supplementary support of the unit is provided by 2 x sprung safety clips at opposite corners of the unit.

	Client: Westin	Ref: WSW - PRIME 1100 - EM - REAR - SS	Approved by:	Date:	Scale: 1:10 A4
	Drawn by: Daniel Bradley				Units: mm
	Title: WSW - PRIME 1100 - EM - REAR - SS GA V1 20220208				Date: 08-02-22

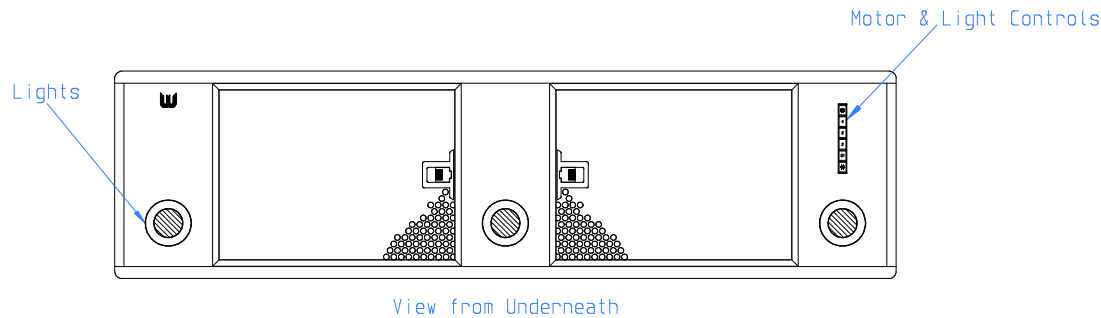
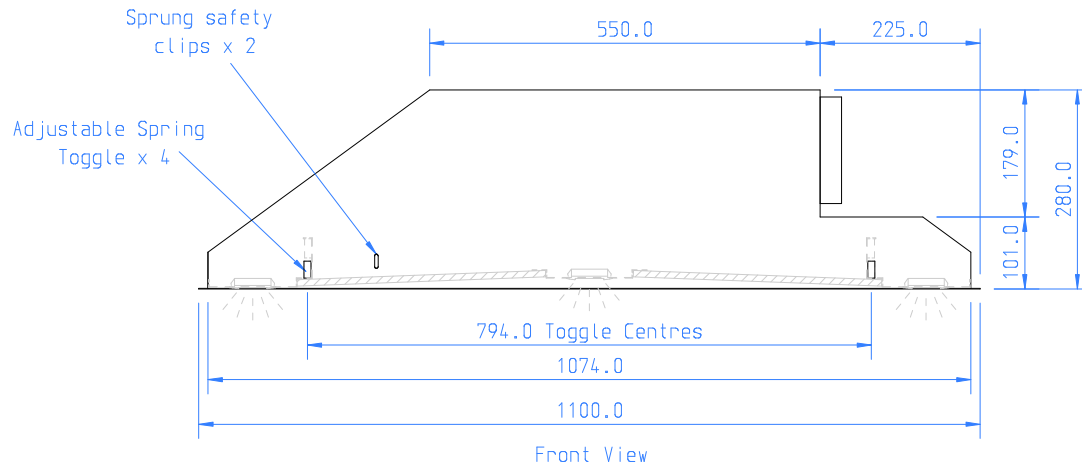
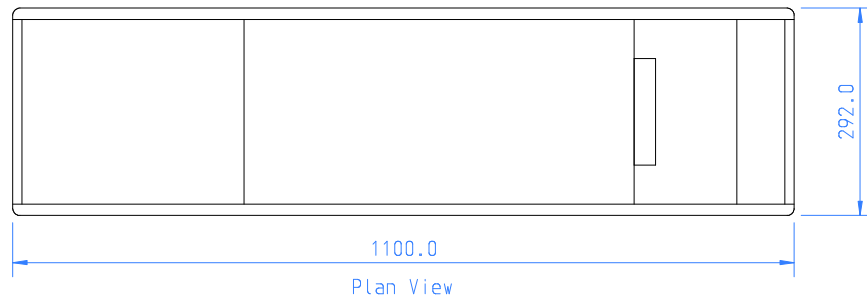

Motor: 1 x SEM Remote Motor - Separate Item

Lighting: Tunable White LED

Motor & Light Controls: Tactile Pushbutton (Remote Control Compatible)

Duct: 1 x 150mm  $\varnothing$  Right Outlet

Soffit Opening - 1080mm x 266mm

Soffit Thickness - 15mm Minimum upto 22mm Maximum

The extractor is fixed in place by 4 adjustable spring toggles.

Supplementary support of the unit is provided by 2 x sprung safety clips at opposite corners of the unit.

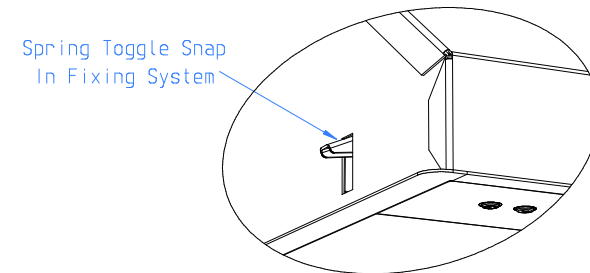
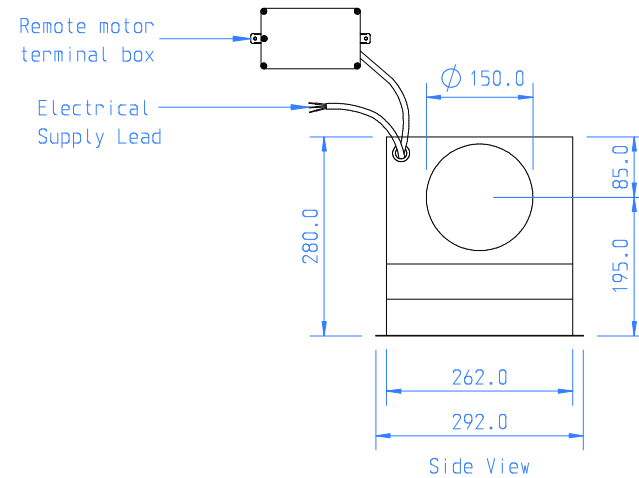

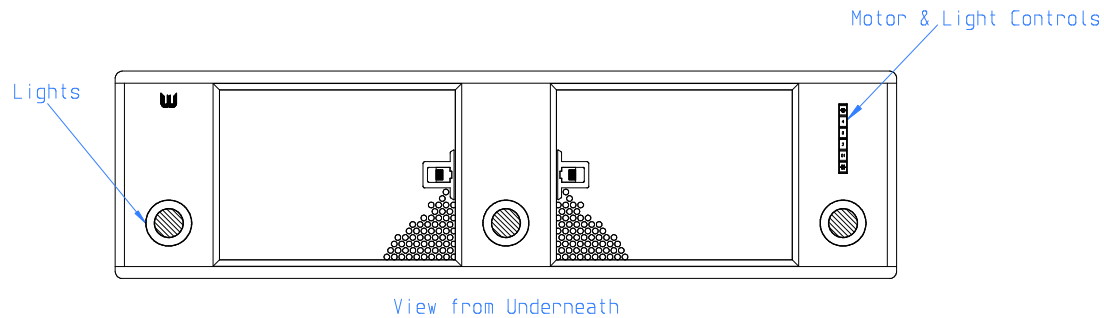
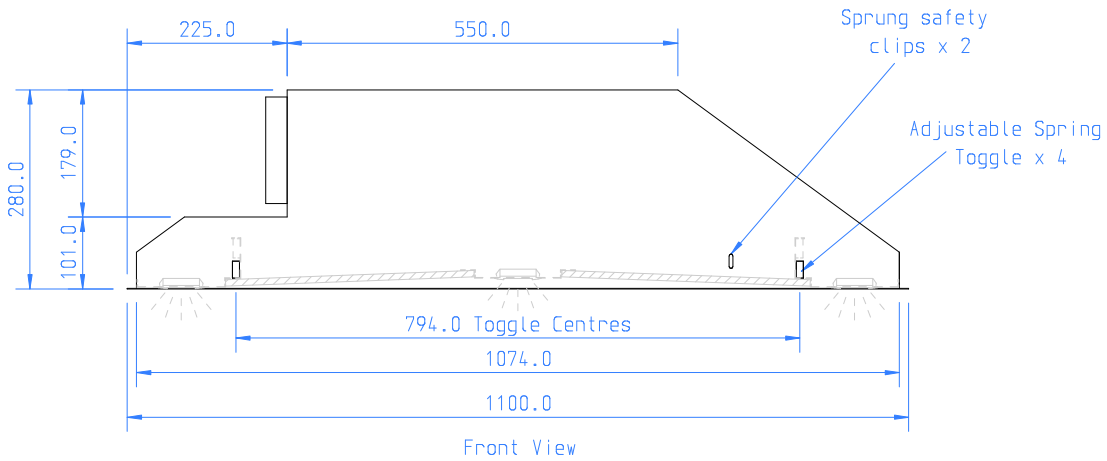
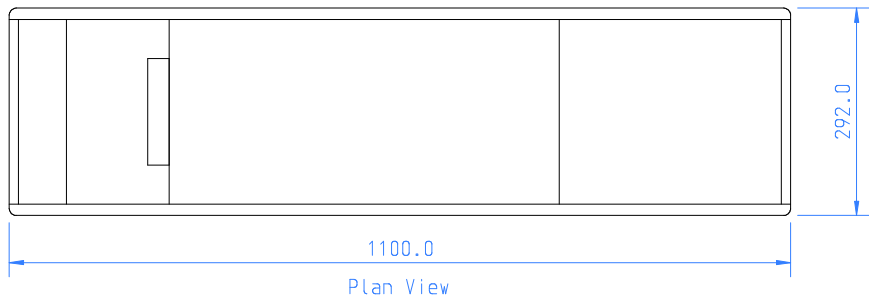

Motor: 1 x SEM Remote Motor - Separate Item

Lighting: Tunable White LED

Motor & Light Controls: Tactile Pushbutton (Remote Control Compatible)

Duct: 1 x 150mm  $\varnothing$  Left Outlet

Soffit Opening - 1080mm x 266mm

Soffit Thickness - 15mm Minimum upto 22mm Maximum

The extractor is fixed in place by 4 adjustable spring toggles.

Supplementary support of the unit is provided by 2 x sprung safety clips at opposite corners of the unit.

