

Motor: 1 x Internal Motor

Lighting: Tunable White LED

Motor & Light Controls: Tactile Pushbutton (Remote Control Compatible)

Duct: 1 x 150mm \varnothing Top Outlet

Soffit Opening - 780mm x 266mm

Soffit Thickness - 15mm Minimum upto 22mm Maximum

The extractor is fixed in place by 4 adjustable spring toggles.

Supplementary support of the unit is provided by 2 x sprung safety clips at opposite corners of the unit.

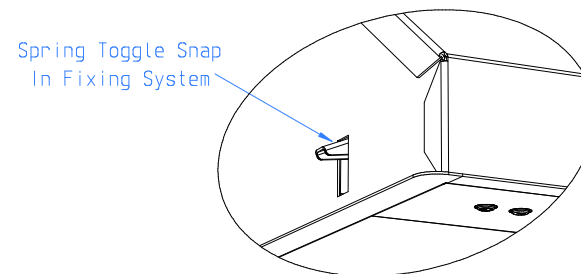
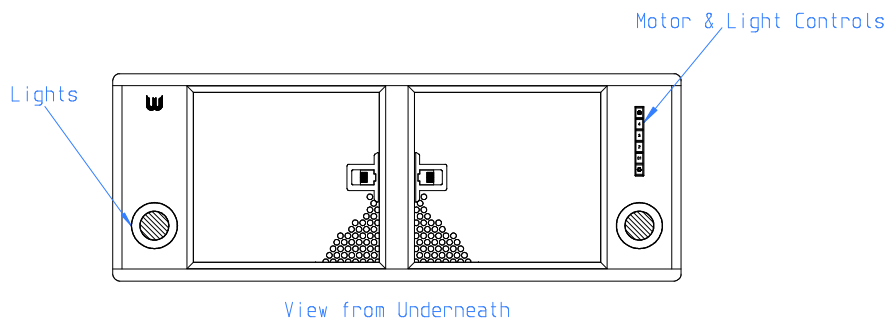
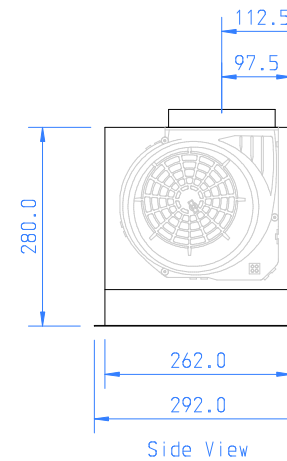
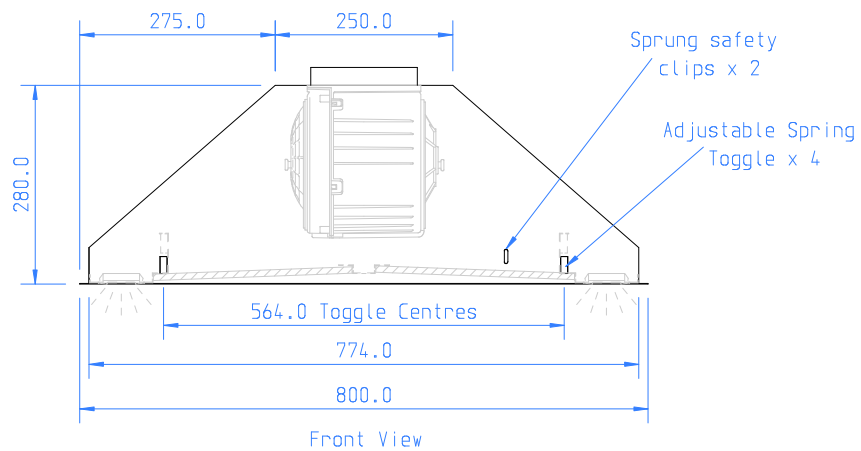

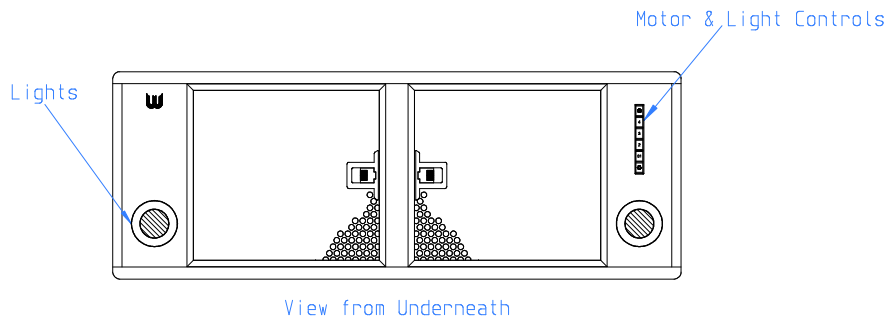
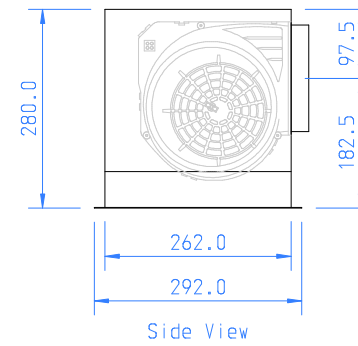
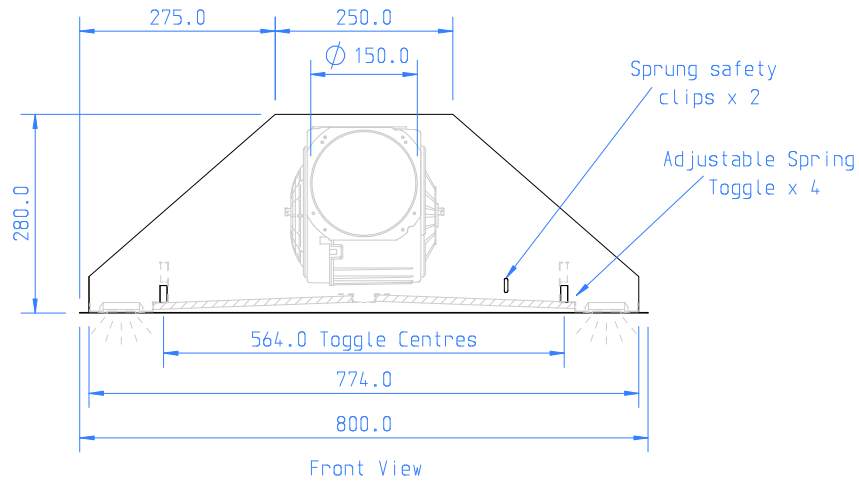
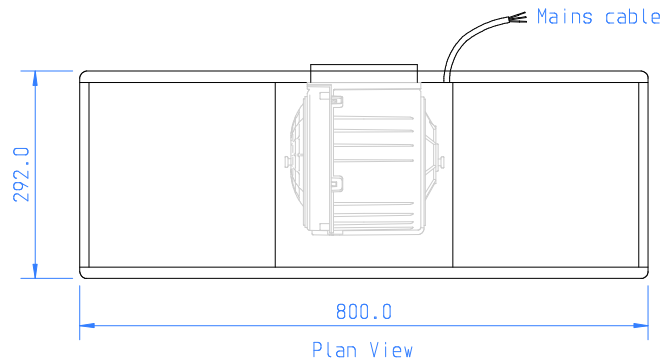

Motor: 1 x Internal Motor

Lighting: Tunable White LED

Motor & Light Controls: Tactile Pushbutton (Remote Control Compatible)

Duct: 1 x 150mm \varnothing Rear Outlet

Soffit Opening - 780mm x 266mm

Soffit Thickness - 15mm Minimum upto 22mm Maximum

The extractor is fixed in place by 4 adjustable spring toggles.

Supplementary support of the unit is provided by 2 x sprung safety clips at opposite corners of the unit.

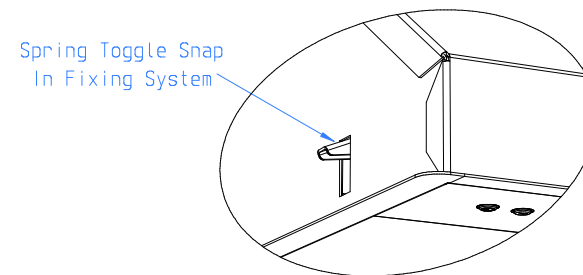

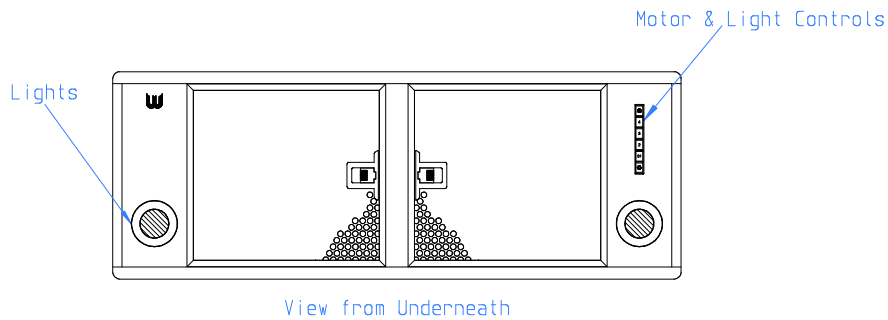
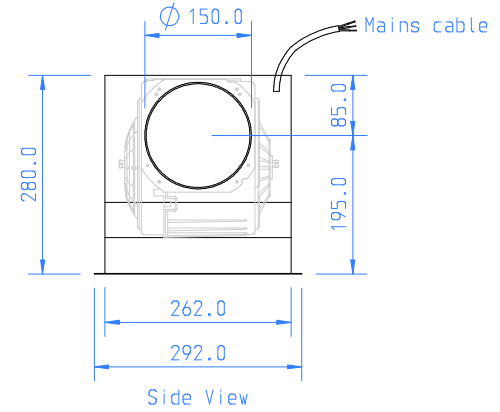
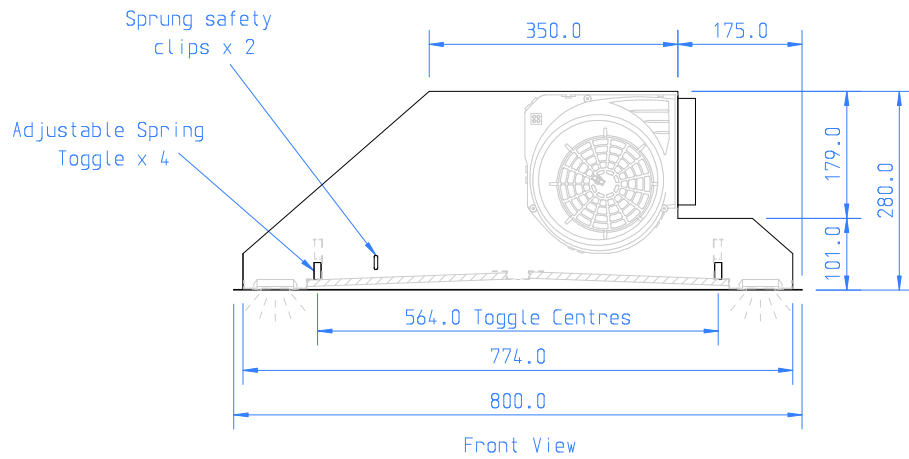
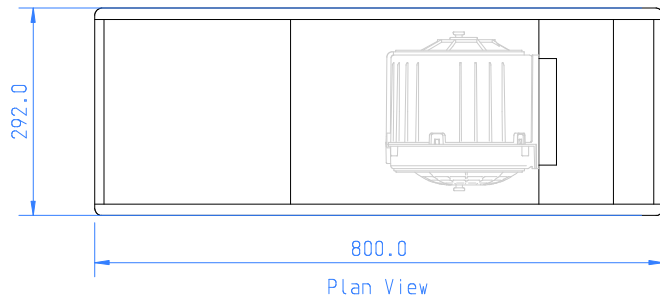

Motor: 1 x Internal Motor

Lighting: Tunable White LED

Motor & Light Controls: Tactile Pushbutton (Remote Control Compatible)

Duct: 1 x 150mm \varnothing Right Outlet

Soffit Opening - 780mm x 266mm

Soffit Thickness - 15mm Minimum upto 22mm Maximum

The extractor is fixed in place by 4 adjustable spring toggles.

Supplementary support of the unit is provided by 2 x sprung safety clips at opposite corners of the unit.

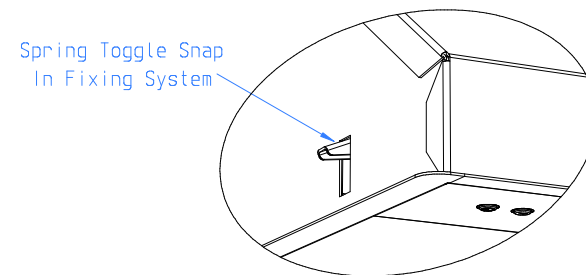

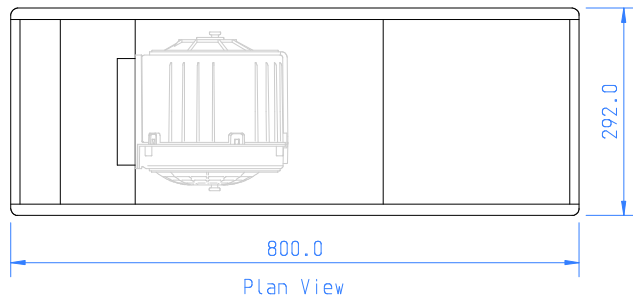

Motor: 1 x Internal Motor

Lighting: Tunable White LED

Motor & Light Controls: Tactile Pushbutton (Remote Control Compatible)

Duct: 1 x 150mm \varnothing Left Outlet

Soffit Opening - 780mm x 266mm

Soffit Thickness - 15mm Minimum upto 22mm Maximum

The extractor is fixed in place by 4 adjustable spring toggles.

Supplementary support of the unit is provided by 2 x sprung safety clips at opposite corners of the unit.

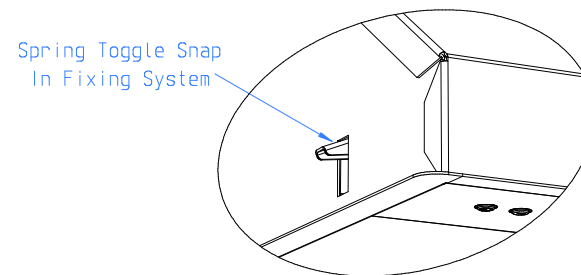
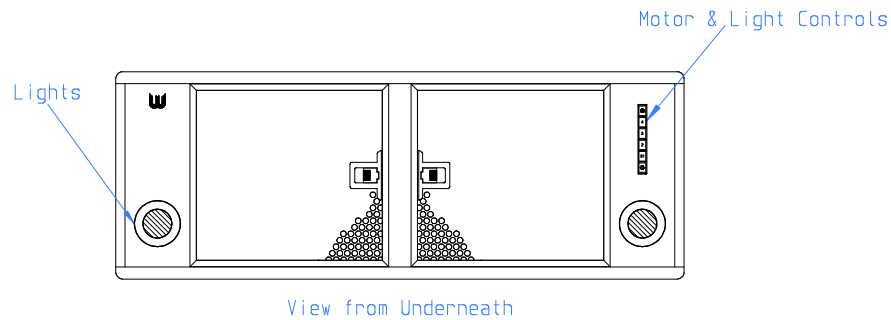
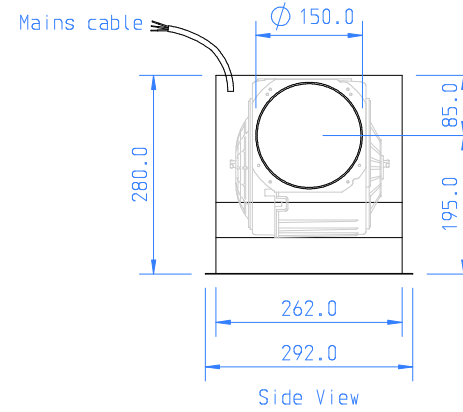
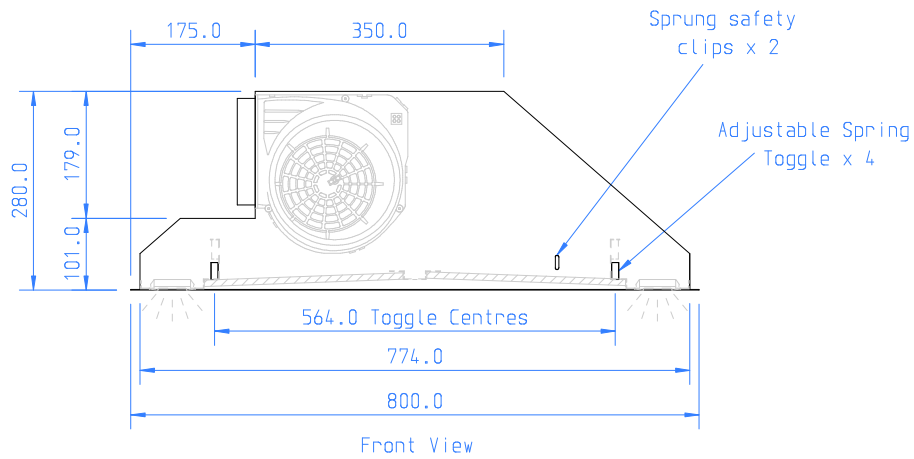

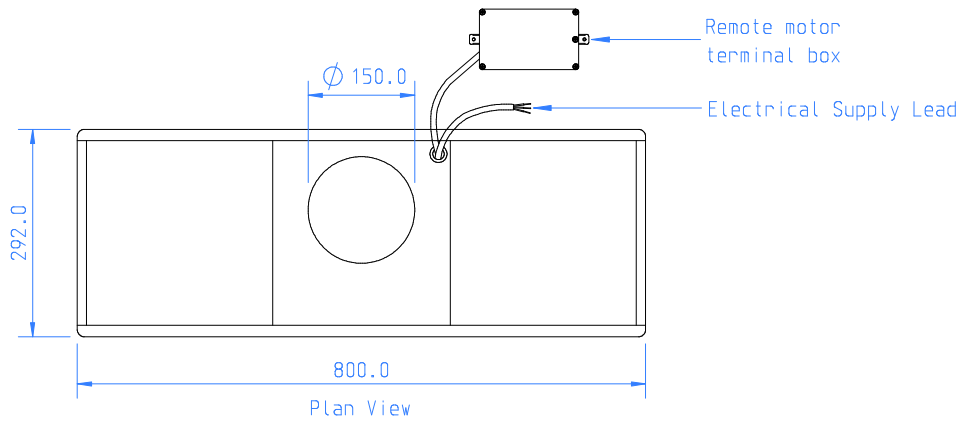

Motor: 1 x SEM Remote Motor - Separate Item

Lighting: Tunable White LED

Motor & Light Controls: Tactile Pushbutton (Remote Control Compatible)

Duct: 1 x 150mm ϕ Top Outlet

Soffit Opening - 780mm x 266mm

Soffit Thickness - 15mm Minimum upto 22mm Maximum

The extractor is fixed in place by 4 adjustable spring toggles.

Supplementary support of the unit is provided by 2 x sprung safety clips at opposite corners of the unit.

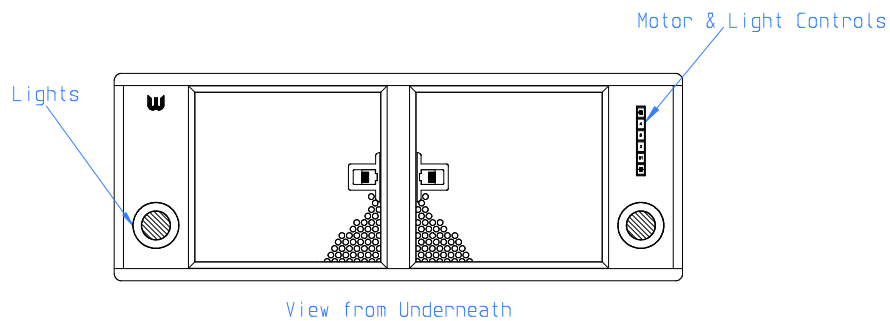
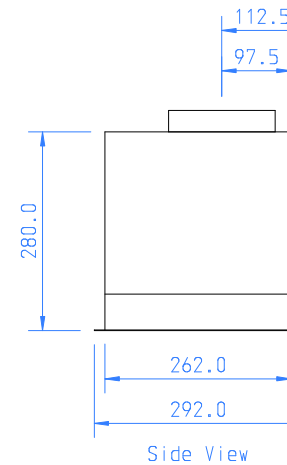
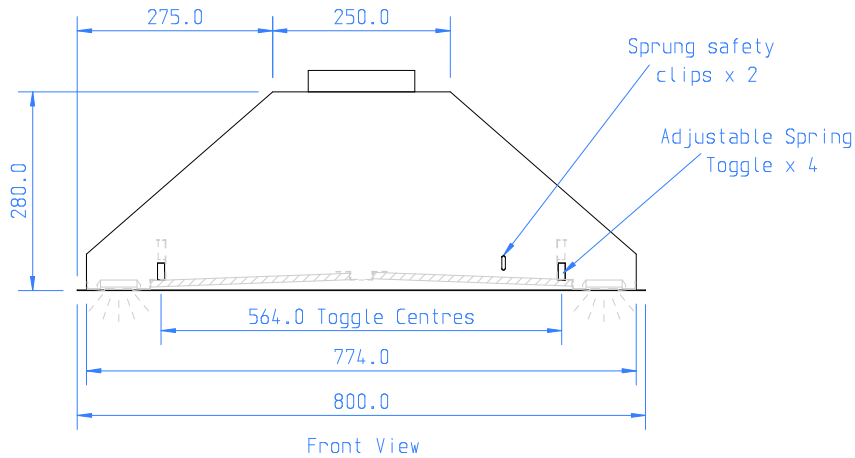

Spring Toggle Snap In Fixing System

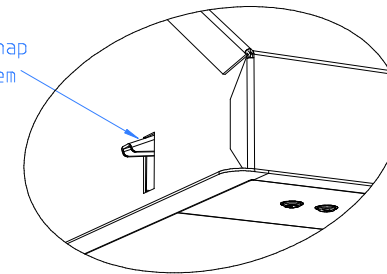

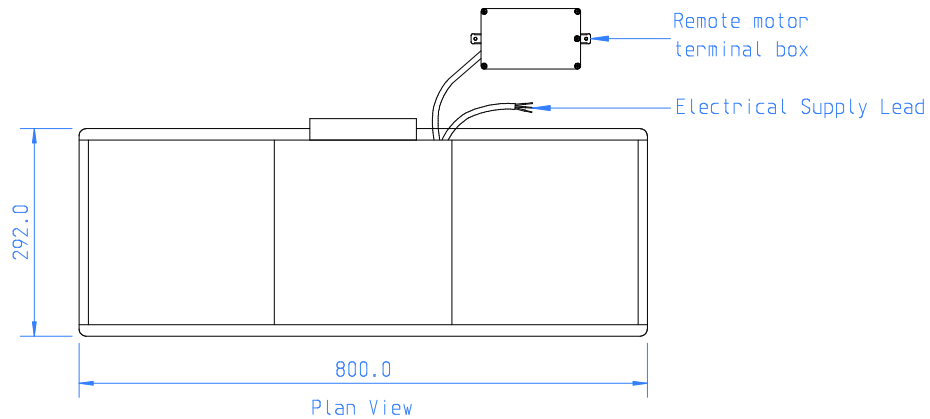

Motor: 1 x SEM Remote Motor - Separate Item

Lighting: Tunable White LED

Motor & Light Controls: Tactile Pushbutton (Remote Control Compatible)

Duct: 1 x 150mm \varnothing Rear Outlet

Soffit Opening - 780mm x 266mm

Soffit Thickness - 15mm Minimum upto 22mm Maximum

The extractor is fixed in place by 4 adjustable spring toggles.

Supplementary support of the unit is provided by 2 x sprung safety clips at opposite corners of the unit.

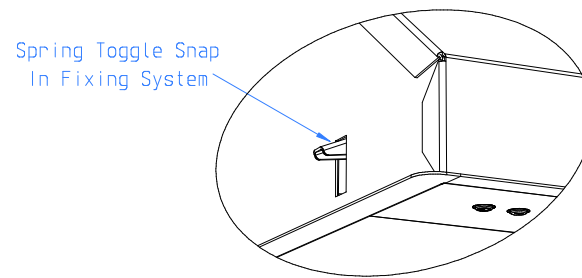
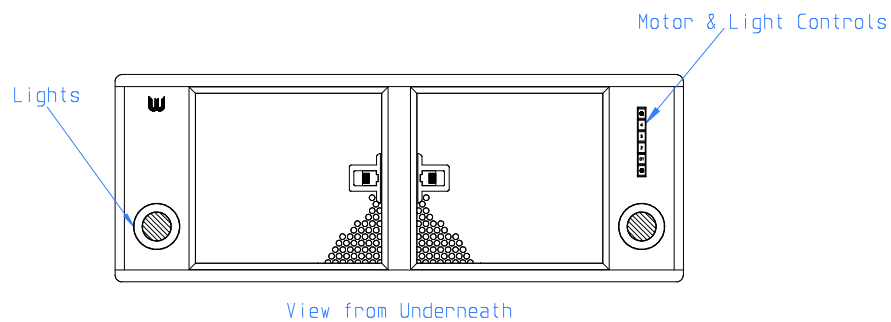
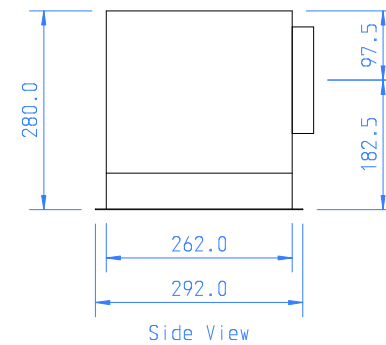
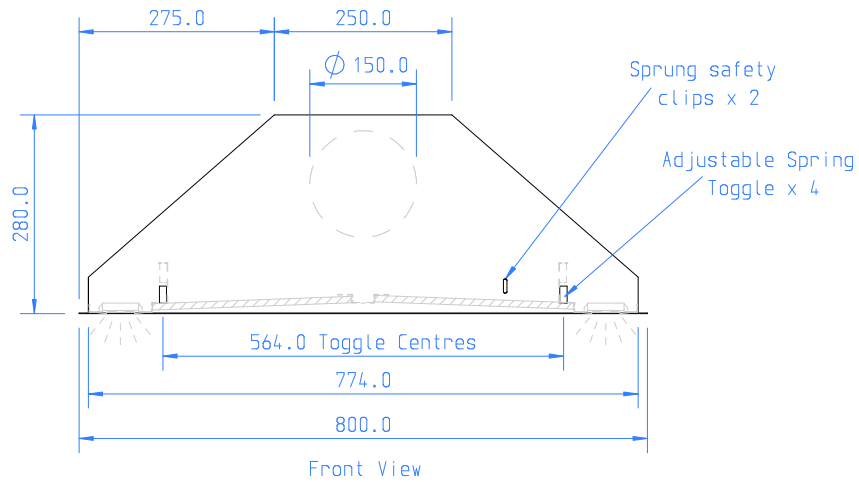

Client: Westin
 Drawn by: Daniel Bradley
 Title: WSW - PRIME 800 - EM - REAR - SS GA V1 20220208

Ref: WSW - PRIME 800 - EM - REAR - SS

Approved by:

Date:

Scale: 1:10 A4
 Units: mm
 Date: 08-02-22

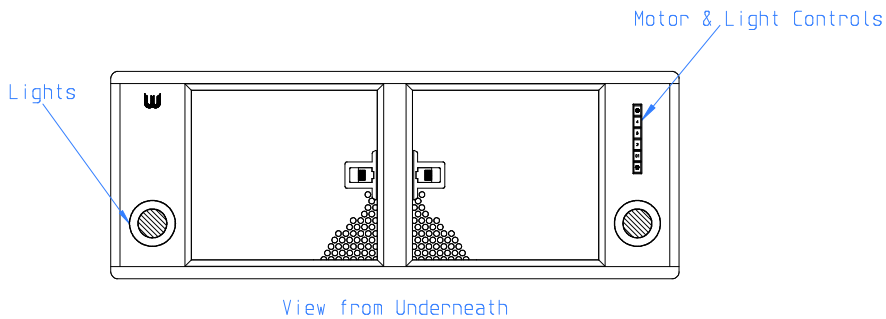
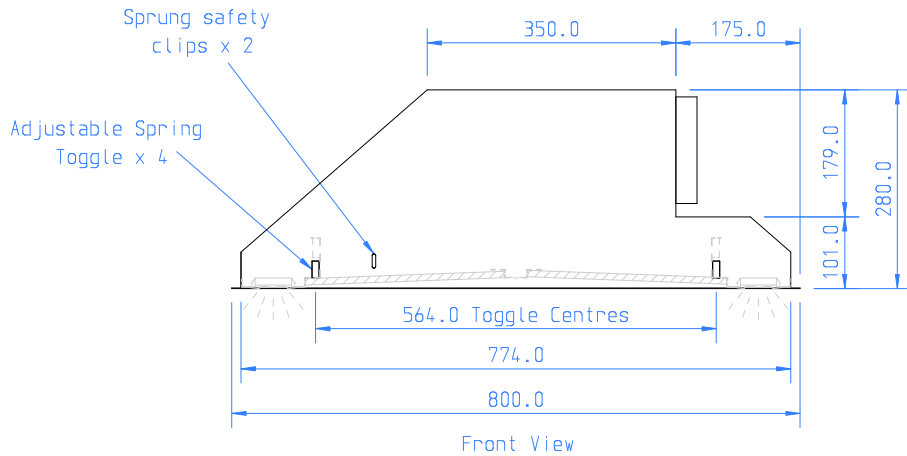
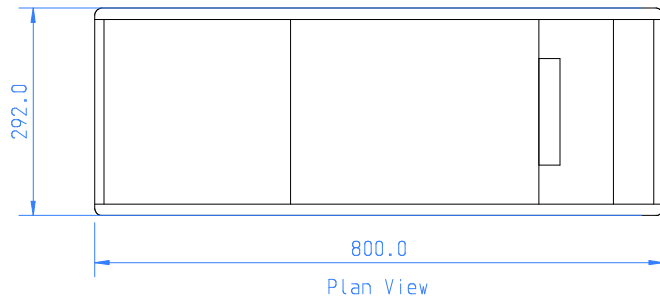

Motor: 1 x SEM Remote Motor - Separate Item

Lighting: Tunable White LED

Motor & Light Controls: Tactile Pushbutton (Remote Control Compatible)

Duct: 1 x 150mm \varnothing Right Outlet

Soffit Opening - 780mm x 266mm

Soffit Thickness - 15mm Minimum upto 22mm Maximum

The extractor is fixed in place by 4 adjustable spring toggles.

Supplementary support of the unit is provided by 2 x sprung safety clips at opposite corners of the unit.

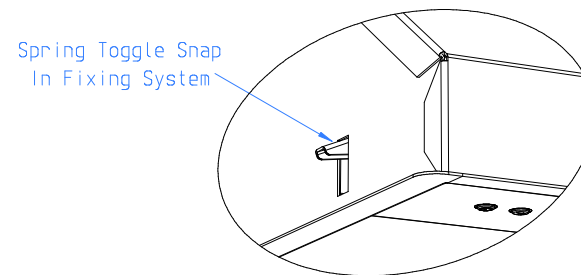
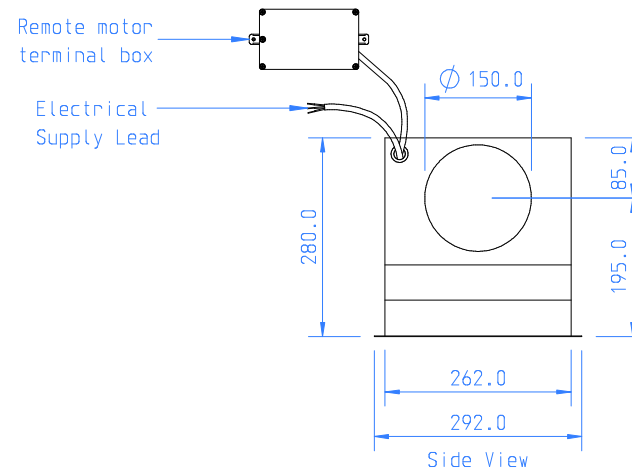

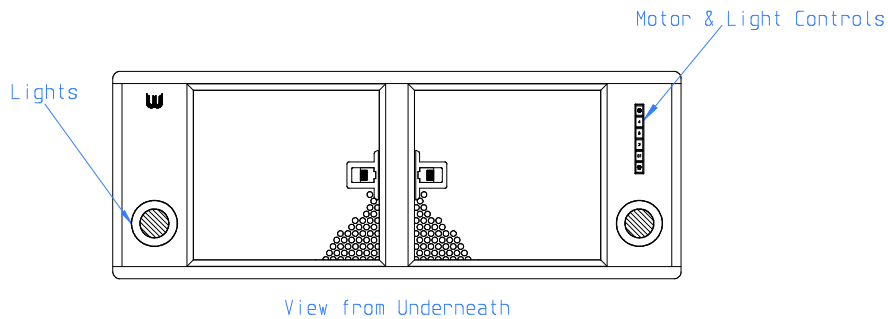
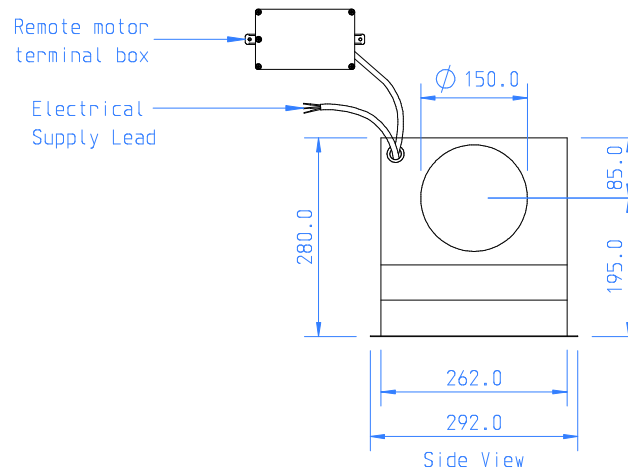
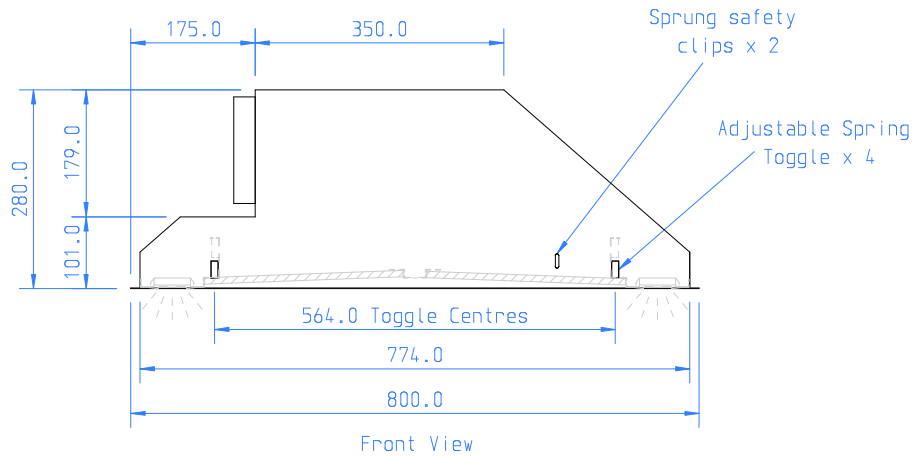
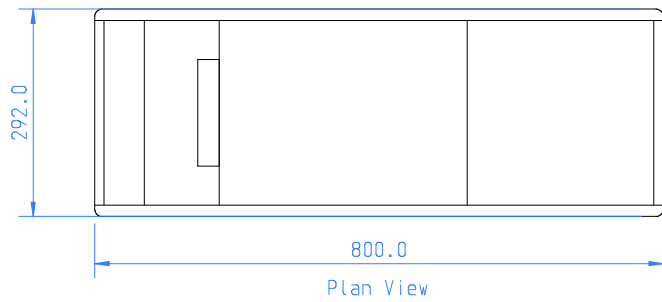

Motor: 1 x SEM Remote Motor - Separate Item

Lighting: Tunable White LED

Motor & Light Controls: Tactile Pushbutton (Remote Control Compatible)

Duct: 1 x 150mm \varnothing Left Outlet

Soffit Opening - 780mm x 266mm

Soffit Thickness - 15mm Minimum upto 22mm Maximum

The extractor is fixed in place by 4 adjustable spring toggles.

Supplementary support of the unit is provided by 2 x sprung safety clips at opposite corners of the unit.

