

Motor	1 x External Motor
Lighting	2 x Variable Warmth (2700K-6000K) Dimmable LED Strip lights
Motor & Light Control	Pushbutton / Radio Remote Control
Duct	1 x 150mm ϕ Duct
Duct Position	Top or Rear (Please Specify when Ordering)

REVISIONS				
ZONE	REV.	DESCRIPTION	DATE	APPROVED

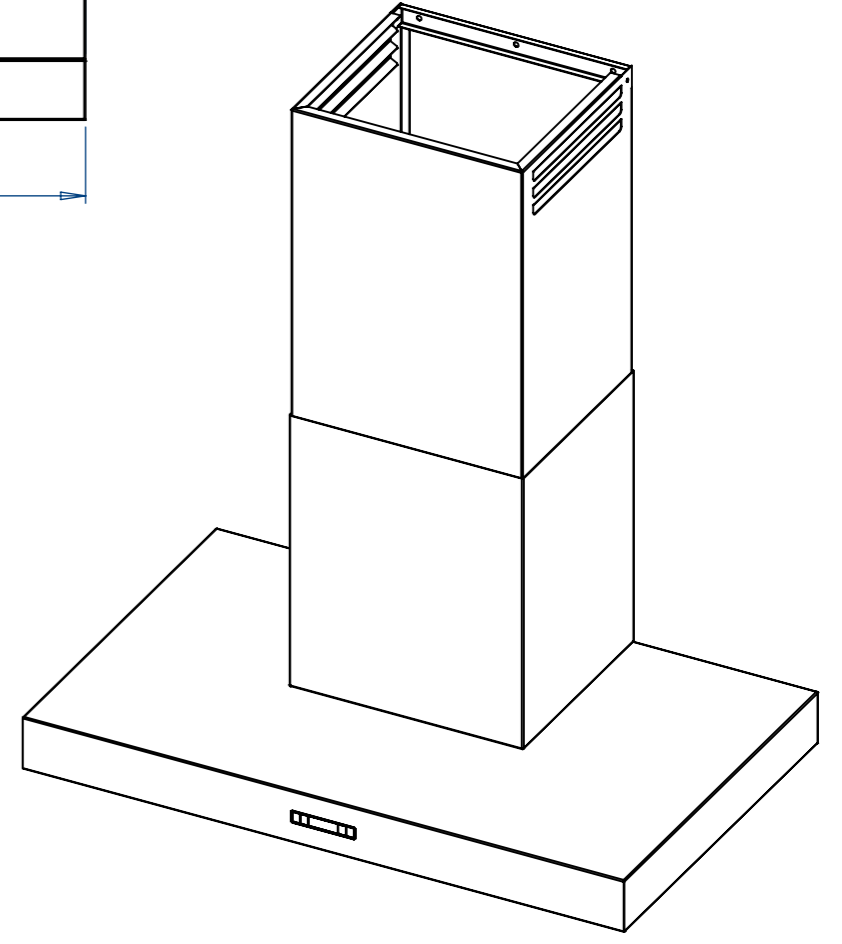
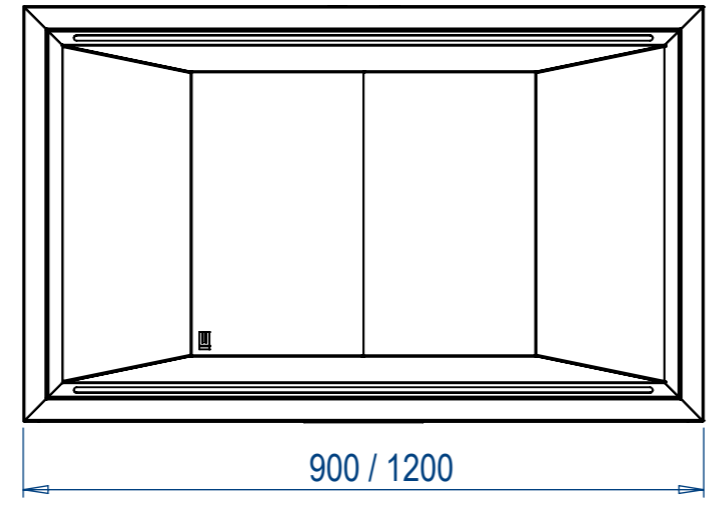
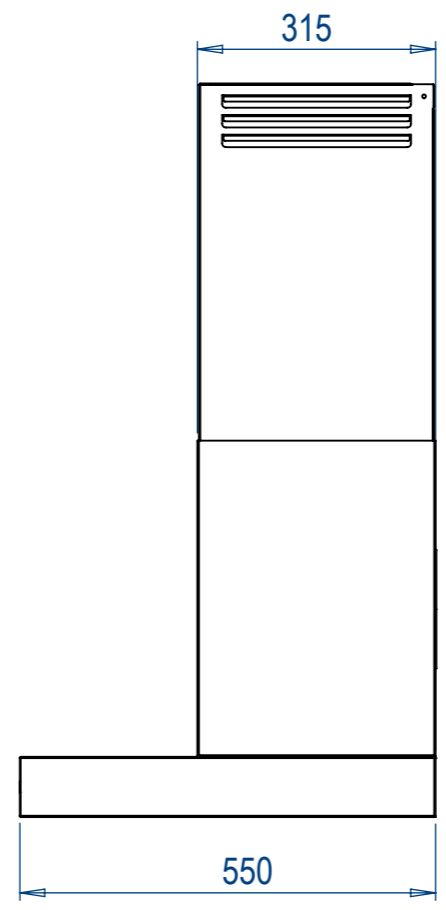
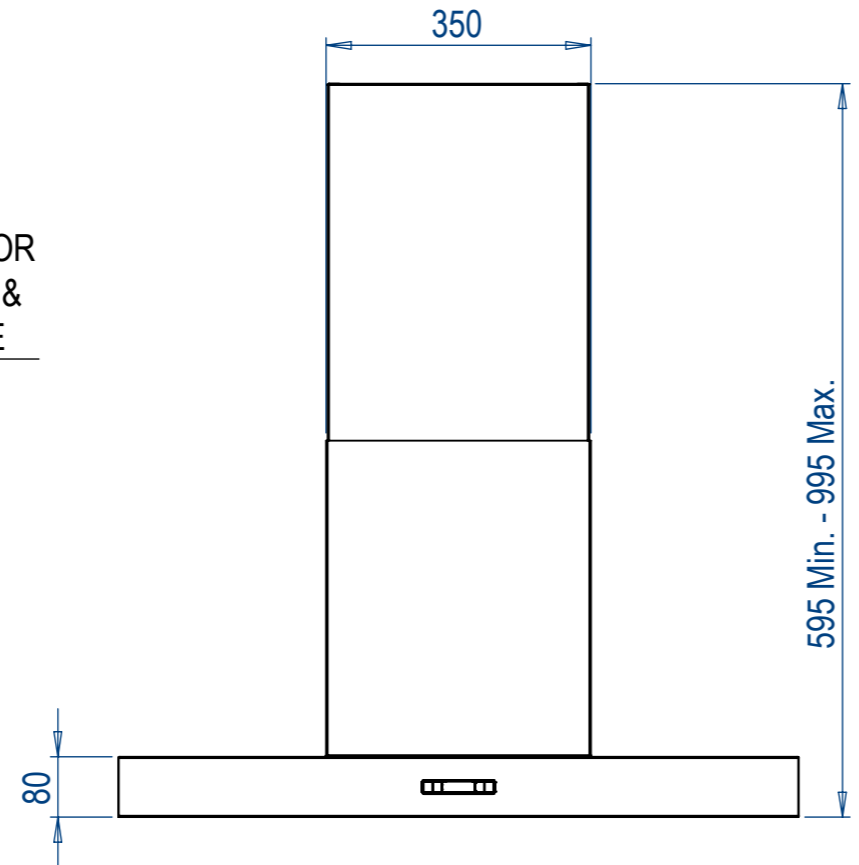
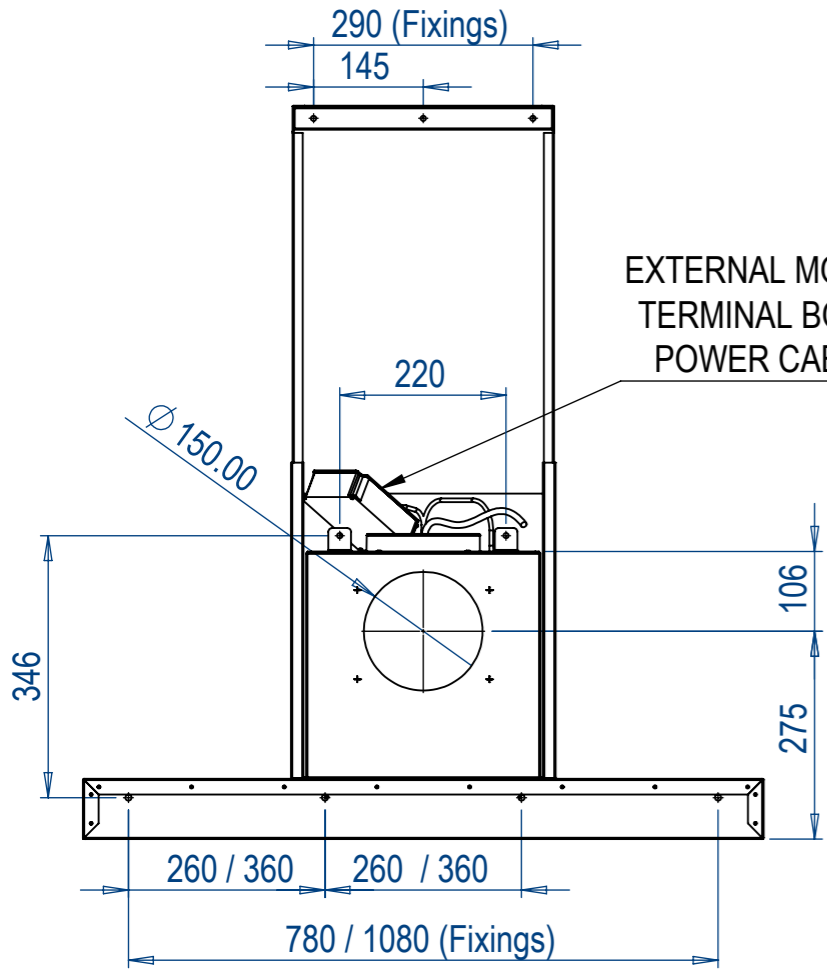

CLIENT. WS WESTIN LTD
 DRAWN BY. M.BARNES
 TITLE. WSW - VAULT EDGE 900 - 1200 EM ~ GA V2 20200701

REFERENCE. PRODUCTION
 APPROVED BY. MPB
 DATE APPROVED. 07/12/20

DO NOT SCALE DRAWING
 ALL DIMENSIONS ARE IN MILLIMETERS
 DRAWING MUST NOT BE RE-CIRCULATED WITHOUT THE PERMISSION OF WS WESTIN LTD

SCALE. DNS
 DWG NO.
 DATE. 29/07/2022
 A3/A4