

Stratus 360 HEPA UV Ceiling Built-In Unit 1180x420 2D General Arrangement

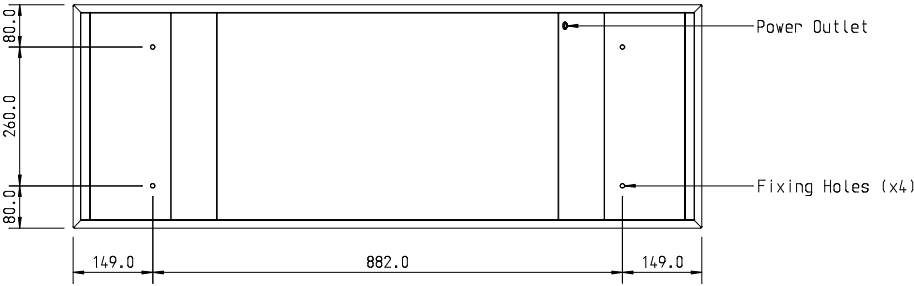

Plan View

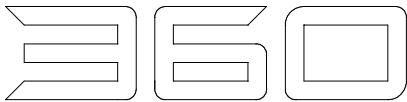
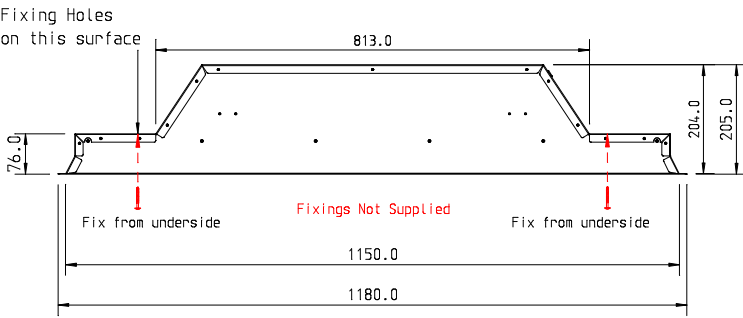
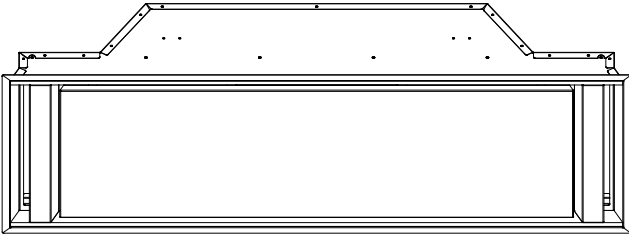

Front View

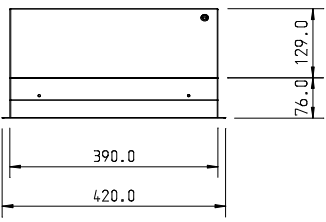

Side View

- Motor: 1 x Internal Motor
- Lighting: 2x Variable Warmth & Dimmable Strip Lights
- Motor & Light Control: Radio Remote Control
- Mesh Filter / HEPA Filter / UV module
- Ceiling Cutout: 1155mm x 395mm x 205mm



View from Underside

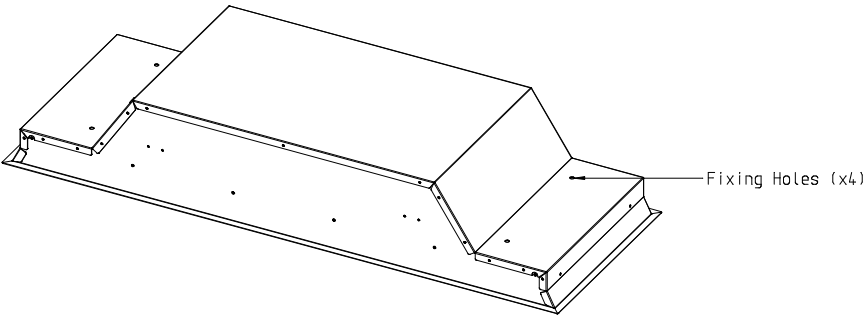

Ceiling Opening (Cutout Size) - 1155 x 395 x 205h



Client: WS Westin Ltd
 Drawn by: M Barnes
 Title: Stratus 360 - 1180x420 GA V1 20240103

Ref: General Arrangement

Approved by:

Date:

Scale: 1:10 A3

Units: mm

Date: 03-01-24