



WESTIN

STRATUS

Ceiling Built-in Unit

Installation, Operation and Maintenance

INTRODUCTION	2
IMPORTANT INFORMATION	2
EXTRACTION PERFORMANCE	2
INSTALLATION	2
SPECIFICATIONS	5
OPERATING INSTRUCTIONS	6
MAINTENANCE	6
ILLUSTRATIONS	7
REMOTE MOTOR	12
GUARANTEE	13

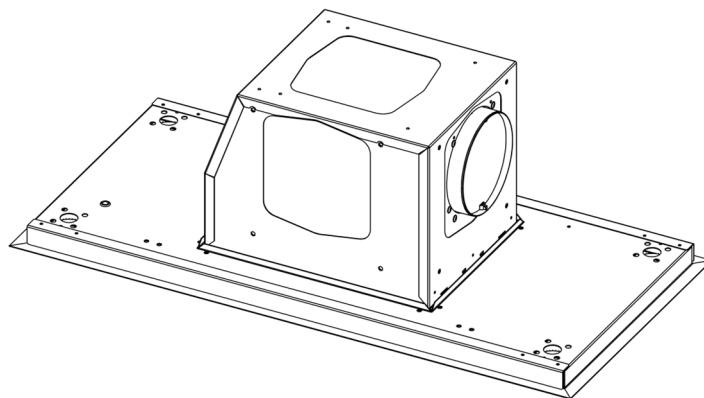

Unpacking

Remove all items from the packaging. Retain the packaging.
If items are missing or damaged, please contact Westin for assistance.
The following items are included:

Ceiling Built-in Unit STRATUS

Installation, Operating & Maintenance Instructions



1. INTRODUCTION

During the cooking process, there will be heat, vapours and fumes produced. Your *Westin Ceiling Extractor* has been designed to complement your kitchen, both in looks and performance in order to create a good environment for creative cooking.

2. IMPORTANT INFORMATION

The exhaust air must not be discharged into a flue which is used for exhausting fumes from appliances supplied with energy other than electricity e.g. oil- or gas-fired central heating boilers, gas-fired water heaters, etc.

Requirements of the relevant authorities concerning the discharge of exhaust air must be complied with.

Pay particular attention to fire risk when frying. To minimise the risk of fire, all instructions relating to cleaning the grease filters and removing grease deposits must be adhered to.

WARNING.

Proper care must be taken to ensure that the negative pressures caused by high performance extraction systems do not adversely affect the safe operation of certain types of fuel-burning appliances (gas, oil or solid fuel), including those installed in the kitchen and possibly also those installed in other parts of the house.

Where such fuel-burning appliances are installed, adequate ventilation **MUST** be provided in the room of installation, located and sized such that the negative pressure in the room created by the extractor does not exceed 4Pa.

In case of doubt, do not operate the extractor and fuel-burning appliance(s) simultaneously and consult an appropriate (for the fuel type) expert for advice.

ELECTRICAL SAFETY.

This appliance requires an earth connection.

Ensure that the supply voltage corresponds to that marked on the rating label inside the extractor.

The extractor must be isolated from the electrical supply before carrying out any cleaning or maintenance operations.

Do not flambé under the extractor.

The clearance between the hob burners and the bottom surface of the extractor must be at least 750mm to prevent overheating of the extractor and its components.

Please also note that a 90° bend in flexible ducting will require 215mm minimum headroom to give a smooth radius with no kinking.

You are advised to install measures designed to reduce the incidence of cold draughts entering the property via any ductwork.

- For extractors with internal or inline motors, this should, at the very least, consist of an external duct termination with integrated non-return flaps (e.g. gravity shutter wall grille/louvre) and/or an inline backdraught shutter.

- For wall-mounted motors, an inline backdraught shutter is recommended.

3. EXTRACTION PERFORMANCE

As its name suggests, this type of extractor is designed to fit into the ceiling void, with only the underside and outer flange visible when installed.

Because fumes spread out as they rise, a unit larger than the hob area is desirable, although not always possible. The perimeter extraction system is designed to conceal the grease filters and to minimise fume escape. Warm cooking fumes that do escape tend, initially, to accumulate in the highest part of the room, so situating the unit at the highest point is of benefit. It will perform best when it is situated directly over the hob.

The primary influence on the overall performance of the extractor is the design of the ducting which takes the exhaust air from the extractor to the outside. The duct route should be a prime consideration during the initial stages of the kitchen design (Westin do not recommend recirculating air back into the kitchen).

Please note the following:

- Easy access to the duct route during installation is important. Lack of access may require the “blind” fitting of flexible ducting, with increased risk of unseen kinks and impaired efficiency.

- **The extractor is provided with a spigot(s) suitable for connecting 150mm round ducting (or equivalent cross section). Ducting must not be reduced.**

Note: Failure to adequately fit the ducting stated above will void your written Guarantee under the Standard Guarantee conditions.

- The most efficient configuration is to duct straight through an outside wall so, try to position the cooker against an outside wall when designing your kitchen.
- Your extractor can be set to vent to the rear, front, left or right. Use the exhaust position which gives the shortest achievable duct route and least number of bends. Joist positions will often determine what is achievable.
- Rigid 150mm round ducting or an equivalent flat channel system (available from *Westin*) will perform best, with semi-rigid (often referred to as flue liner) being the second-best solution. Flexible ducting is economical but its use should be minimised as it gives the worst performance and should only be used for short duct runs or initial connection and should be pulled taut to prevent significant losses in extraction efficiency.
- For maximum efficiency, ducting should be kept as short as possible and as straight as possible with a constant cross-sectional area being no less than that recommended by Westin. Bends in the duct will also degrade performance so the number of bends in a duct run should be kept to a minimum and be gradual and smooth to prevent turbulence. Avoid kinks in flexible ducting; pull flexible ducting taut over straight runs to ensure that the internal surface is as smooth as possible.

4. INSTALLATION

The extractor is designed for installation within a cut-out in the underside of the kitchen ceiling. Alternatively, it may be installed within a lowered area of ceiling or a soffit panel within your furniture – remember though that it is desirable to install directly into the ceiling (see section 3).

Ceiling Built-in Unit STRATUS

Installation, Operating & Maintenance Instructions



Dimensioned drawings and illustrations to help with your installation can be found on page 7 onwards.

Please note the following.

- The extractor is made up of two main parts*:
 - The “*top box*”, which houses the exhaust ducting spigot, grease filter, electrical connection points and any internal motor.
 - The “*baseplate*”, which is essentially the visible parts when installed and houses the lights, hinged filter concealment panel and outer frame.
- The ducting spigot must be set to the required outlet position prior to installation (Left, Right, Front, Rear or Top).
- The Stratus Flush “top box” has 3 possible duct spigot positions. It is easily separated from the baseplate and can be rotated through 180 degrees in order to achieve all 5 possible outlet directions. It is secured via screws accessible only when the filter concealment panel is in the open position.
- The extractor fixing holes are hidden behind the LED down lights, which can easily be popped out to reveal four possible fixing locations behind each (only one fixing hole in each corner needs to be used).
- **If your extractor is a recirculating model**, (optional extra and not the standard configuration) then adequate provision must be made for exhausted air to return into the kitchen - e.g. ducted out to a vent in the kitchen located somewhere that minimises uncomfortable draughts onto occupants. Failure to do so may cause the unit to overheat and fail (invalidating your warranty).

4.1. Opening the filter concealment panel.

The panel is held shut with magnetic catches.

Open the panel by grasping it close to the corners on the catch side (the long edge opposite the hinges) and pulling to release the panel from the magnets. Take care not to let the panel fall open freely. It should be supported and moved carefully into the open position.

4.2. Setting the Duct Spigot Position.

Your extractor ducting spigot can be set to vent to the Left (factory default), Right, Front, Rear or Top.

The front of the unit (when installed) is the side with the magnetic catches.

Note: If you wish to vent upwards and space is restricted, then you may find your installation easier if you use a side outlet position and put a bend in your ducting.

The “top box” exhaust spigot assembly refers to the removable 150mm ducting spigot plate, which in the case of Internal blower models, has the motor attached to it.

- As described earlier, the Stratus Flush “top box” has 3 possible duct spigot positions, with the remainder being achieved by rotation of the top box through 180 degrees.

To change the exhaust spigot position of the “top box” proceed as follows:

- Suspend the extractor on its back *such that the “top box”* is clear of the ground. This is best achieved by placing the product across the top of the open box it came in so that the “top box” hangs down into the box.
- Open the filter concealment panel and remove the filter(s).

- Each exhaust position has 4 captive nuts onto which can be bolted either the exhaust spigot assembly or a blanking plate.

Bolt the exhaust spigot assembly into the required location by swapping it with a blanking plate as necessary using a screwdriver.

Note: For internal blower models, where space within the top box is limited, only the screws nearest to the filter opening need to be fully removed. The screws farthest away need only to be backed off as the plate has slots for easier removal/replacement of the motor.

To rotate the “top box” proceed as follows:

- Suspend the extractor on its back *such that the “top box”* is clear of the ground. This is best achieved by placing the product across the top of the open box it came in so that the “top box” hangs down into the box.
- Open the filter concealment panel to reveal the fixing screws securing the “top box” to the “baseplate” and remove the screws.
- Carefully lift the “top box” out of the “baseplate” opening, rotate it to face the required direction and carefully refit it in its new position, taking care not to trap any wires. Secure it with the screws previously removed.

Important.
The “top box” needs to be angled during removal and refitting to allow the duct spigot, electrical connection points and cables to clear the opening in the “baseplate”.

4.3. Revealing the Fixing Holes.

The extractor is fitted with 4 high intensity LED lamp assemblies (one in each corner) which conceal the fixing holes behind them. These are easily popped out to reveal four possible fixing locations behind each.

The best way to remove the lamps for initial installation is to pop them out from behind. 25mm finger holes (centred on each lamp) are provided in the baseplate to enable this.

The lamps remain attached to their electrical cables so care must be taken not to damage the wires during installation.

Note: The fixing holes can be revealed after the unit is installed by carefully pulling the lamps out from underneath.

Four fixing holes will now be visible in the corner of each lamp opening.

You should only need to use 1 of the holes in each corner to secure the unit in position.

4.4. Prepare Opening

Prepare an opening in the ceiling into which the unit will be fitted (see table below). Refer to the drawings on Page 7 for detailed opening design and clearance height information.

Unit Size (mm) (Width x Depth)	Cut-out Size (mm) (Width x Depth)
880 x 420	860 x 400
880 x 780	860 x 760
1180 x 420	1160 x 400
1180 x 780	1160 x 760

Reinforce the opening as necessary and make suitable provisions for the screws that will hold the unit in place.

Tip: To avoid the need to box down from the ceiling, consider the joist direction, ceiling thickness (and possibly lowering the ceiling slightly). As much of the baseplate only intrudes above

Ceiling Built-in Unit STRATUS

Installation, Operating & Maintenance Instructions



the finished ceiling by 35mm, (see diagrams on Page 7 Onwards) boxing down can usually be avoided with minimal alterations to the ceiling arrangement.

4.5. Ducting

Install ducting, taking note of the advice given in section 2 & 3.

We recommend using semi-rigid round ducting for this extractor – the initial connection to the extractor spigot must be in semi-rigid (or flexible duct) to allow the entire unit (or top box if fitting separately) to be pushed into position with the duct connected.

Run the ducting such that there is enough to easily reach just beyond the centre point of the extractor, thus allowing for a short length to be pulled through the opening for later connection to the top box spigot. Try to avoid tight bends immediately adjacent to where the top box will be as this will make pushing the unit/top box into position more difficult.

When terminating ducting on an outside wall, a suitable weather louvre should be fitted. Various ducting components and complete kits are available from *Westin* to suit most installations.

If you plan to use expanding foam, make sure that any soft flexible ducting is supported internally to prevent it crushing or use semi-rigid/rigid ducting where foam is used.

For roof or chimney duct terminations, please contact *Westin* or seek alternative specialist advice.

If you are fitting a wall-mounted external motor with semi-rigid or flexible ducting, then you must leave a short length (approx. 200mm) of expanded (stretched out) ducting proud of the wall to facilitate connection to the motor spigot before pushing both into position flush with the wall.

Standard external motors come with a cable assembly that must pass through the wall and run back to the extractor – usually this passes alongside the ducting, so it is recommended to oversize your cut-out by at least 25mm to allow for this (and for the easy installation of the duct).

4.6. Remote External Wall and Inline Motors

If your extractor has been purchased to operate with a standard inline or external remote motor (SEM) then you will find a black plastic box outside the extractor (on flying leads) containing electrical terminals for connection to the remote motor cable assembly. This box is referred to as the remote motor terminal box.

Run the remote motor cable such that sufficient hangs down through the ceiling opening prepared for the extractor to allow for easy connection to the remote motor terminal box.

Each terminal inside the remote motor terminal box has one side connected to a coloured wire, which leads back to the hood control system. The remote motor cable assembly also has coloured wires and these are connected to the empty terminals such corresponding colours are opposite and connect to each other; i.e. red connects to red, blue to blue, and so on...

Not all terminals will be used because each remote motor type is configured differently.

No separate power supply is required for the external motor.

An electrician (or Part P registered electrical installer) should undertake any work associated with the electrical installation of SEM remote motors.

Please refer to the REMOTE MOTOR ILLUSTRATIONS on page 9 for more information.

If you need to extend the remote motor cable, then additional cable can be purchased from *Westin*. Alternatively, it may be

extended using 7 core x 0.5mm flex. It is vital to ensure that any new cable is inserted such that the core colour integrity is maintained; i.e. a core that started as red must terminate as red, blue as blue, purple as purple, and so on.

Any remote motor should be installed in accordance with the installation instructions that accompany it. It must be installed in an easily accessible location for future maintenance. *Westin* are not responsible for providing the means of access (e.g. scaffolding or any alterations to the building and/or furniture necessary to make access possible) in the event of any maintenance requirement.

4.7. Electrical Installation

**ELECTRICAL HAZARD.
DISCONNECT ELECTRICAL SUPPLY BEFORE
PROCEEDING FURTHER**

The extractor is a stationary appliance supplied with an electrical supply flex and moulded 3 pin UK plug (3A) for connection to the electrical supply.

The appliance must be fed from a 230Vac single phase electrical supply. You may wish to terminate the electrical supply using a standard mains electrical socket positioned close to the extractors intended location.

Alternatively, you may terminate the electrical supply from a switched-fused spur. The spur should be located adjacent to the hood/cooker so that the supply can be disconnected from the hood using the switch. The means of disconnection from the supply must have a minimum contact separation of 3mm in all poles. A competent Part P registered electrical technician must perform the electrical installation.

The mains supply is connected as follows:

INCOMING SUPPLY CORD CONNECTIONS	
Core	Core Colour
Live	Brown
Neutral	Blue
Protective Earth	Green/Yellow

Make sure the switched - fused spur supplying the extractor is in the 'off' position before connecting the appliance to the electrical supply.

4.8. Fixing the Extractor in Position

Please note the following prior to commencing fixing the extractor in position:

- You will need at least 2 people to fit this extractor; to lift, hold and fix the unit in position:
- A working platform or scaffold should be used so that the ceiling opening can be reached and the unit fixed without the use of ladders.
- Screws for fixing the extractor into position are not provided. You must use suitable fixings capable of supporting 30kg.

If you are screwing into timber, then you should use screws no smaller than 5mm (No. 10) with a head diameter of 10mm or more (and ensure that at least 35mm of thread is screwed into the timber) and that the timber will not split when the screws are inserted.

- The unit will need supporting close to the opening when attaching the ducting and making electrical connections –

Ceiling Built-in Unit STRATUS

Installation, Operating & Maintenance Instructions



do not be tempted to install excessive ducting as this will impair performance.

As described earlier, a length of semi-rigid ducting protruding a short distance through the centre of the ceiling opening is sufficient for the final connection to the extractor spigot. This will allow the unit to be fixed into position with the duct connected and prevents excessive lengths of flexible ducting being pushed into the opening (resulting in a loss of efficiency (see section 3)).

Note that it is possible to separate and withdraw the spigot assembly back into the top box, working through the filter opening. Whilst this should not be necessary, it is worth noting as it may help you overcome difficulties, particularly if your ducting has been cut too short as you will be able to attach it to the spigot from inside the extractor.

You must consider and allow for the future removal of the extractor and any remote motor when planning and undertaking your installation should access for future servicing be required.

If you have not already done so, set the top box to duct out in the required direction (as described in section 4.2) and reveal the corner fixing holes - concealed and recessed within the light cavity (as described in section 4.3).

**ELECTRICAL HAZARD.
DISCONNECT ELECTRICAL SUPPLY BEFORE
PROCEEDING FURTHER**

Now connect the LED lighting cable. *This cannot be done when the unit has been installed.*

The LED lamp cable is fitted with a two-pin plug which connects to a corresponding socket on the top box.

- For internal blower models:

The lighting socket is attached to the end of a flying lead on the outside of the top box.

- For remote motor models:

The lighting socket is flush mounted into the side of the top box, next to the remote motor and mains supply cable entry point.

If using a remote motor, connect it now (as described in 4.6). The illustrations on page 9 will help you.

Support the extractor just below the prepared cut-out so that the spigot and electrical connections are accessible.

Make sure that the electrical supply to the electrical supply spur is isolated (switched off) and connect the electrical supply cord of the extractor to the spur.

Attach the ducting to the spigot using suitable clamps or straps (available from Westin). We do not recommend using duct tape as the only means of fixing - this should only be used to improve the seal in the joint.

Now **for all models**, push the extractor up into the cut-out, taking care not to crush or introduce excessive bends/kinks in the ducting and making sure that no wires are trapped or damaged in the process.

Note: If the duct or any wires are trapped, then you must lower the extractor and make corrections to the cut-out area as necessary, before fixing the appliance in position.

Secure the extractor in place using suitable fixings (not supplied) through one fixing hole in each corner of the baseplate.

Now test the function of the unit as described in the operating instructions (Section 6).

If the lights or motor do not function correctly, then isolate the electrical supply and check all the electrical connections before contacting Westin.

Re-fit the LED lamps you removed earlier, thus concealing the fixing holes.

If you experience any difficulties please call Westin for advice.

5. SPECIFICATIONS

All Models	
Product Weight (Largest size: 27Kg)	
Supply voltage:	230V~ 50Hz
LED lamp voltage	12v
LED lamp power	4 x 1.8w
Recommended fuse size for electrical supply:	3A
Extractor Duct spigot diameter:	150mm
Stratus with Internal Motor	
Motor airflow in free air:	800 m ³ /hr
Blower power input:	275W
Total power:	283W
Stratus with SEM1 EL Inline Motor	
Motor airflow in free air:	800 m ³ /hr
Motor power input:	275W
Total power:	283W
Stratus with SEM2 EL External Wall Motor	
Motor airflow in free air:	900 m ³ /hr
Motor power input:	200W
Total power:	208W
Stratus with SEM7 EL External Wall Motor	
SEM7 airflow, in free air: 200mm Dia Duct	1,700 m ³ /hr
SEM7 airflow, in free air: 150mm Dia Duct	1,500 m ³ /hr
Motor power input:	490W
Total power:	498W
<i>Note: The motor has a 200mm diameter spigot and is supplied with a reducer for connection to 150mm ducting.</i>	
Stratus with SEM8 EL Inline Motor	
SEM8 airflow, in free air: 200mm Dia Duct	1,300 m ³ /hr
SEM8 airflow, in free air: 150mm Dia Duct	1,100 m ³ /hr
Motor power input:	250W
Total power:	258W
<i>Note: The motor has a 200mm diameter spigot and is supplied with a reducer for connection to 150mm ducting.</i>	

Main Reset Switch

The Reset Switch is a red rectangular switch located inside the extractor. The Switch can be accessed by opening the Door and removing the Filter(s). Press the Reset Switch to unlatch 'out'. Press the Reset Switch again to relatch 'in'. The Switch must be in the latched 'in' position in order for the extractor to operate.

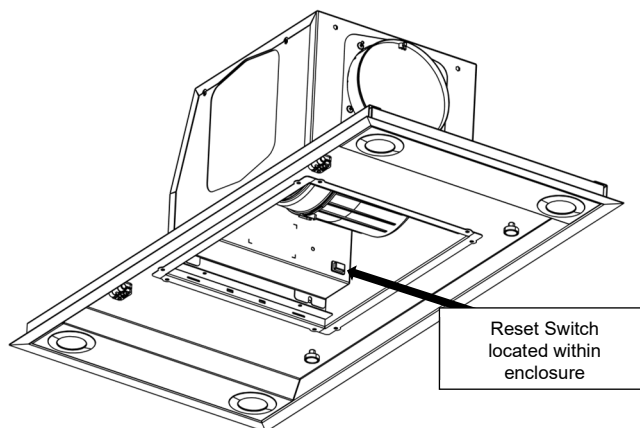

Ceiling Built-in Unit STRATUS Installation, Operating & Maintenance Instructions



5. OPERATING INSTRUCTIONS

Radio Remote Controlled Models

- Switch on the power at the fused spur.
- Then immediately turn on the remote control (⏻).
- Then immediately press and hold (☼) until the lights illuminate.

Should the extractor fail to respond to commands from the remote-control, please check that the power is 'on' and the internal appliance reset switch is in the 'ON' position (factory default). The reset switch is a latching red push-switch located in the chamber behind the door panel / filter.

If you experience interference problems, or the remote appears to be faulty from new, then a different radio transmission code may be required. Refer to the instruction leaflet included with the remote control regarding transmission code changes before seeking assistance.

6. MAINTENANCE

Regular maintenance is essential to ensure good performance and long-life.

CAUTION.

To minimise the risk of fire, all instructions relating to cleaning the grease filters and removing grease deposits must be adhered to.

To maintain the immaculate appearance of the extractor, and to minimise fire risk, ensure that grease deposits on the extractor surfaces are kept to a minimum by regular cleaning.

To clean the stainless-steel surfaces of the extractor, use a soft cloth and a suitable cleaning agent, such as a specially produced stainless-steel cleaner or washing up detergent and warm water.

Painted surfaces should be cleaned using a soft cloth, detergent and warm water.

Glass surfaces should be cleaned with a suitable glass cleaning agent.

- **Do not use abrasive cleaning materials or products.**
- **Do not use bleach-based cleaning materials or products.**

Accessing the filter(s) and baseplate

- The panel is held shut with magnetic catches.
- Open the panel by grasping it close to the corners on the catch side (usually the long edge opposite the hinges) and pull to release the panel from the magnets. Take care not to let the panel fall open freely. It should be supported and lowered carefully into the open position.

Grease Filters

Clean the grease filters every two months using a dishwasher or by hand in hot water with detergent. If the extractor is used heavily, clean them more frequently to prevent excessive grease build-up.

Although designed for long service, mesh grease filters are consumable items and will gradually deteriorate over time, particularly with regular dishwasher use. For users cleaning at two-month intervals in a dishwasher, replacement is recommended every five years to maintain optimum performance, even if no visible damage is present. Filters should always be replaced sooner if any signs of wear or damage are observed.

HP4 Carbon Filters

To restore performance, HP4 carbon filters must be washed in a dishwasher (without other items) and then dried in an oven for one hour at a maximum temperature of 90°C.

Filters should be cleaned whenever they appear dirty or when a reduction in effectiveness is noticed, with a minimum cleaning interval of every two months. Regular washing and regeneration will help maintain performance and extend service life.

These filters are fully regenerable but remain consumable components and will eventually degrade. Under normal use, they are expected to provide reliable performance, with replacement recommended at least every two years, or sooner depending on cooking habits.

LED lamp replacement

The long-life LED units are not designed for end user replacement. In the unlikely event of failure please call the manufacturer to arrange a Service Call.

Remote Control Functions

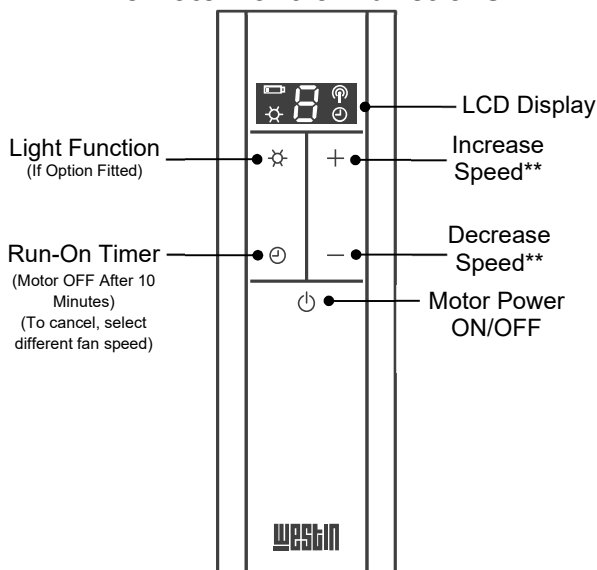

** The automatic speed reduction feature is required by EU Ecodesign and Energy Labelling Commission Legislation 65/2015 66/2014 in order to satisfy Directive 2009/125 EC*

The appliance will automatically switch off if there has been no operator action for 4 hours.

Refer to the instruction leaflet included with the radio remote control regarding pairing the device, transmission codes and factory reset procedures.

Other Control Systems

Because this is a custom-made product, an alternative control system may have been specified during the design phase.

Most commonly this alternative control system will be a continuously variable rotary fan speed controller plus light control mounted on the extractor (usually the baseplate). With most such control systems, you will find on/off switches for the fan and lights and a rotating knob to adjust the fan speed. Sometimes the switch and knob are combined into a single unit, like a domestic lighting dimmer switch, which is pressed for on/off function and turned for speed.

In some cases, the fan control may have been specified as a separate item that does not form part of the extractor (e.g. a wall mounted controller). Such controllers may have been supplied by Westin or a third party and are not covered by this manual.

If you are unsure how to operate your unit then please call Westin for assistance.

Ceiling Built-in Unit STRATUS Installation, Operating & Maintenance Instructions



WSW Stratus Internal Motor – General Arrangement

Motor: 1 x Internal Motor
 Lighting: 4 x Tunable LED Spot Lights
 Motor & Light Control: Radio Remote Control
 Duct: 1 x ϕ 50mm Left Outlet - This can be changed to Top, Back, Front or Right on Site - See Installation Manual
 Lights are Removed to Gain Access to Fixing Holes - See Installation Manual

Ceiling Cutout:

Unit Size (mm)	Cut-out Size (mm)
880 x 420	860 x 400
880 x 780	860 x 760
1180 x 420	1160 x 400
1180 x 780	1160 x 760

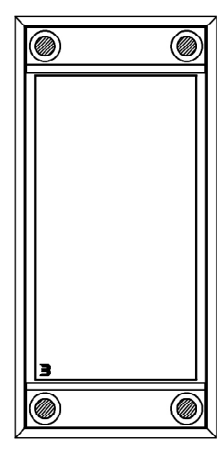
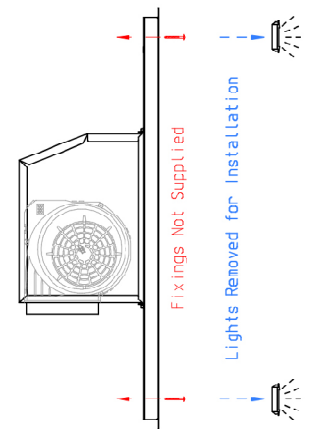
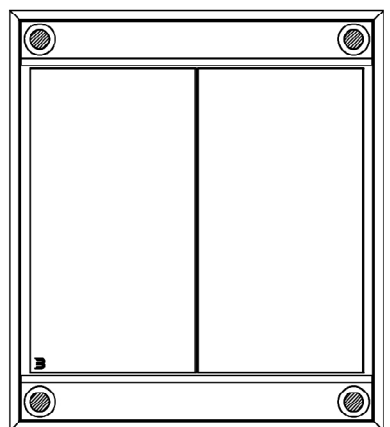
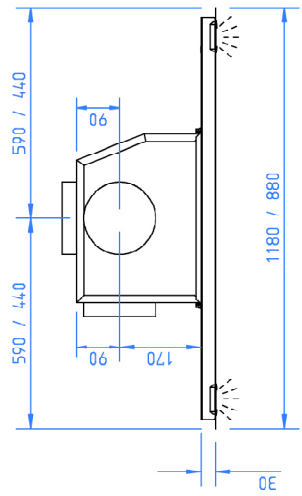
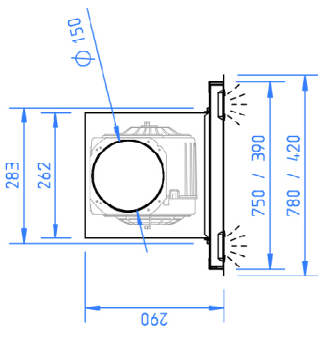
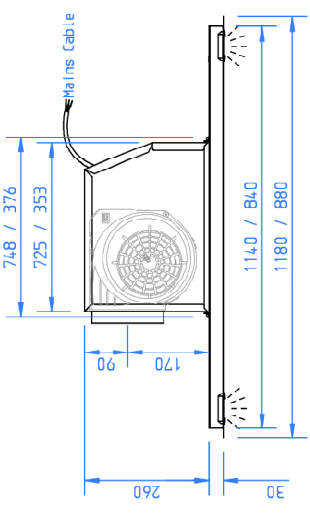
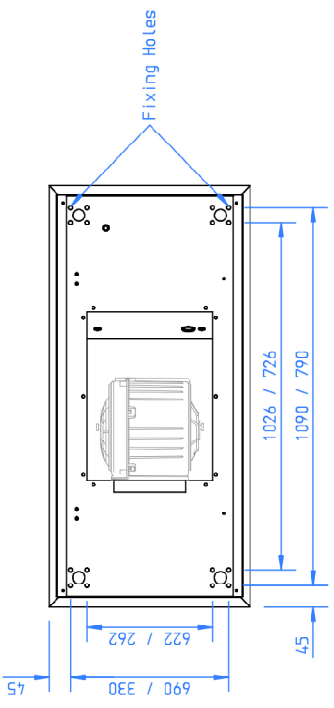

Ceiling Built-in Unit STRATUS Installation, Operating & Maintenance Instructions



WSW Stratus External Motor – General Arrangement

Motor: 1 x SEM Remote Motor – Separate Item

Lighting: 4 x Tunable LED Spot Lights

Motor & Light Control: Radio Remote Control

Duct: 1 x \varnothing 150mm Left Outlet – This can be changed to Top, Back, Front or Right on Site – See Installation Manual

Lights are Removed to 5a in Access to Fixing Holes – See Installation Manual

Ceiling Cutout:

Unit Size (mm)	Cut-out Size (mm)
880 x 420	860 x 400
880 x 780	860 x 760
1180 x 420	1160 x 400
1180 x 780	1160 x 760

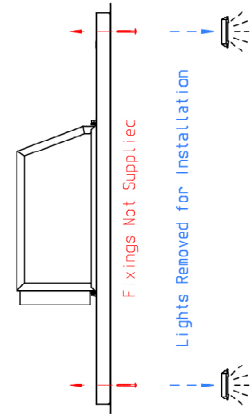
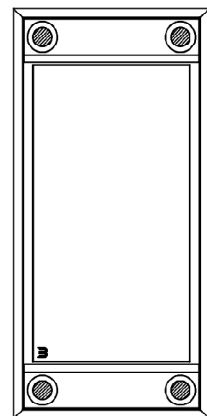
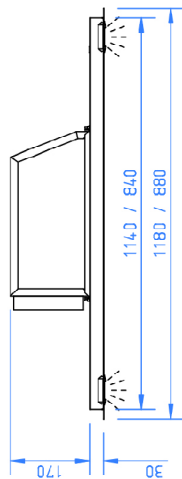
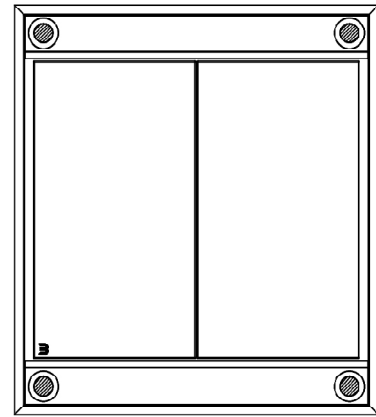
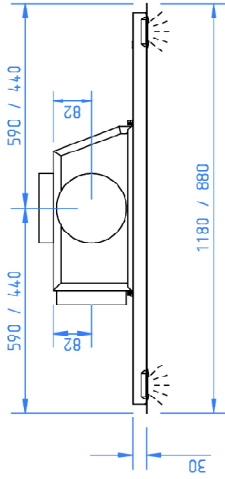
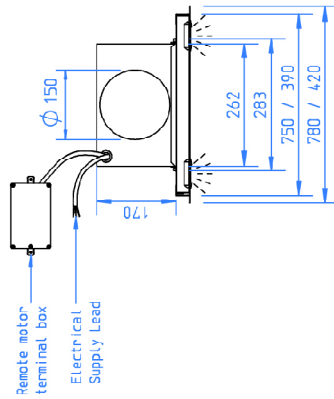
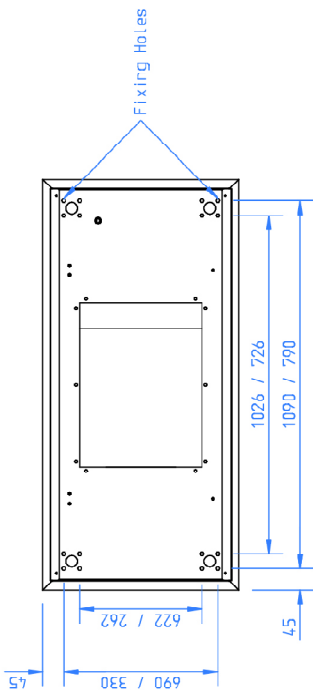

Ceiling Built-in Unit STRATUS Installation, Operating & Maintenance Instructions



WSW Stratus Internal Motor – Exploded View

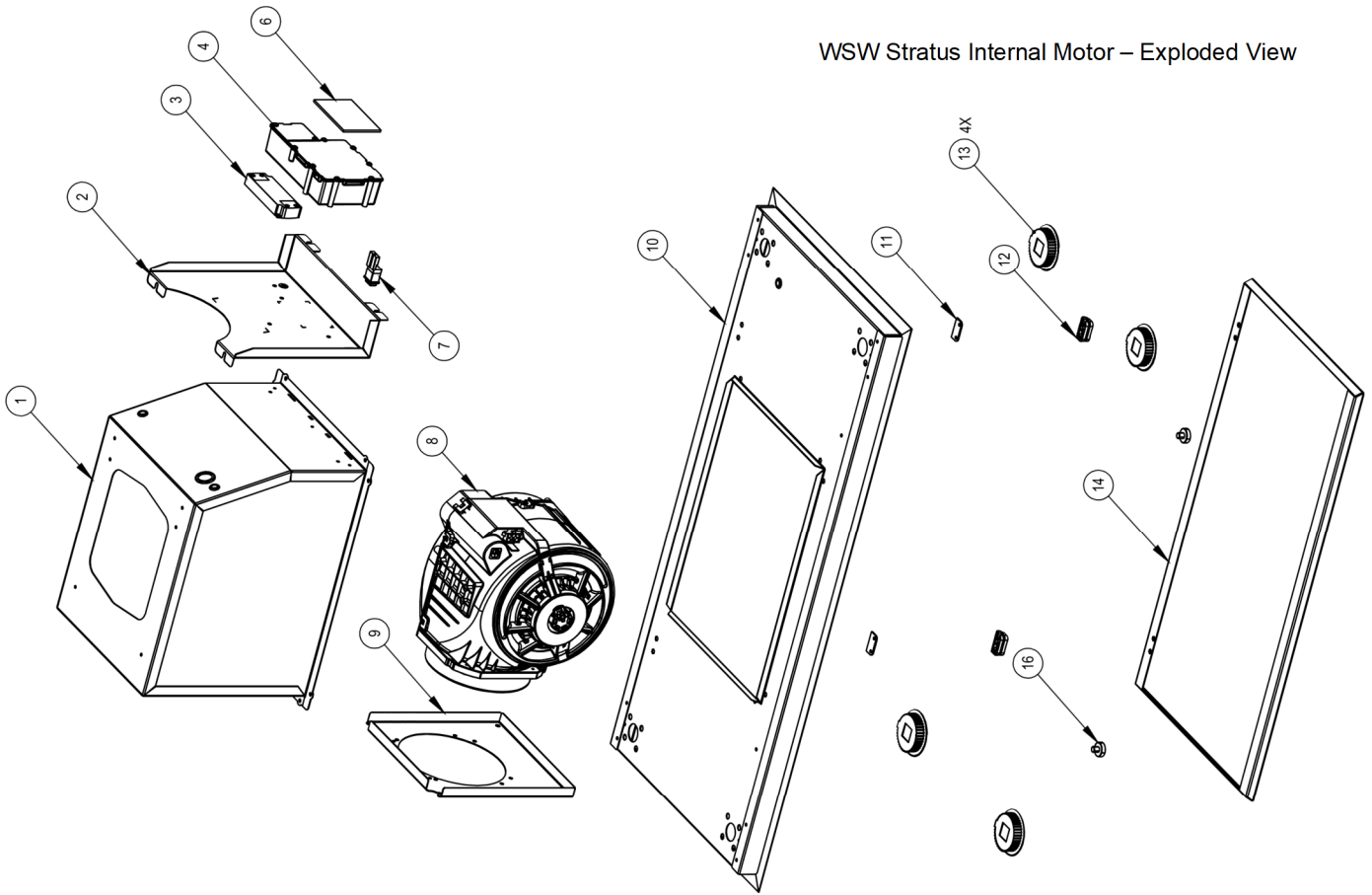

NO.	Part Name	Part Number	Notes & Special Ordering Instructions
1	Extractor Top Box		Made to Order. State Hood Width
2	Control Box Enclosure		Made to Order
3	Lighting Driver	W1094	Non-User serviceable
4	Circuit Board Housing	W0419	Non-User serviceable
5	Remote Control	W1798	
6	Circuit Board	W2037	Non-User Serviceable
7	Reset Switch		Non-User serviceable
8	Motor	W1497	Non-User serviceable
9	Motor Bracket		Non-User serviceable
10	Extractor Body		Made to Order. State Hood Width & Finish
11	2mm Hinge Spacer		Made to Order. State Quantity
12	Door Hinge	W1780 Black / W1789 White	State Quantity
13	LED Lamp	W1729	
14	Extractor Door		Made to Order
15	Grease Filter	880mm = W0711 (x1) 1180mm = W0711 (x2)	
16	Door Magnet	W1107	State Quantity

Ceiling Built-in Unit STRATUS Installation, Operating & Maintenance Instructions



WSW Stratus External Motor – Exploded View

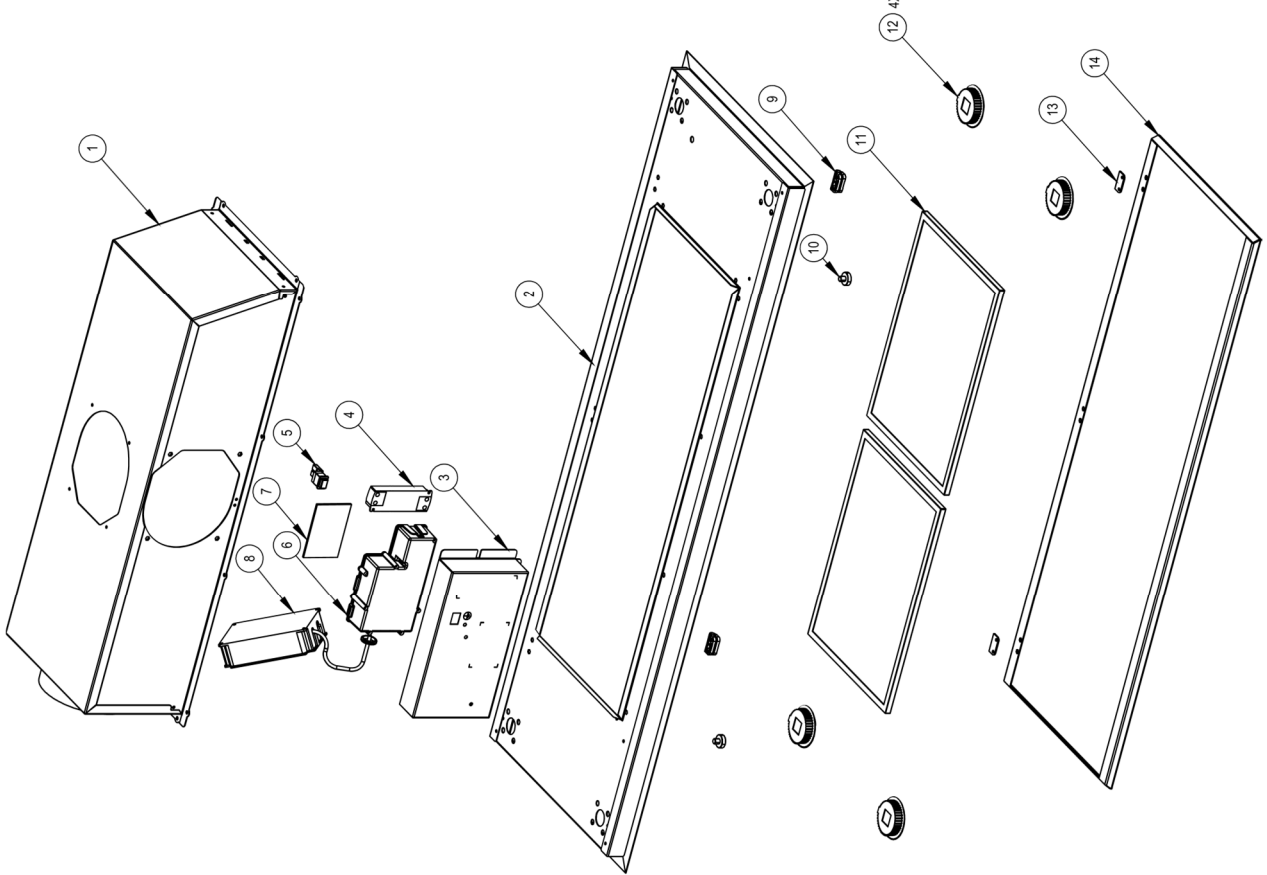

NO.	Part Name	Part Number	Notes & Special Ordering Instructions
1	Extractor Top Box	Made to Order	State Extractor Width
2	Extractor Body	Made to Order	State Extractor Width & Depth
3	Control Box Enclosure	Made to Order	Non-User Serviceable
4	Lighting Driver	W1094	Non-User Serviceable
5	Reset Switch	W0419	Non-User Serviceable
6	Circuit Board Housing	W2037	Non-User Serviceable
7	Circuit Board	W1789	Non-User Serviceable
8	Complete External SEM Assembly	W1789	Non-User Serviceable
9	Door Hinge	W1780 Black / White W1779	Non-User Serviceable
10	Door Magnet	W1107	Non-User Serviceable
11	Grease Filter	880mm = W0711 (x1) 1180mm = W0711 (x2)	
12	LED Lamp	W1729	
13	2mm Hinge Spacer	Made to Order	State Quantity
14	Extractor Door	Made to Order	State Extractor Width & Depth
15	Remote Control	W1798	

Ceiling Built-in Unit STRATUS Installation, Operating & Maintenance Instructions

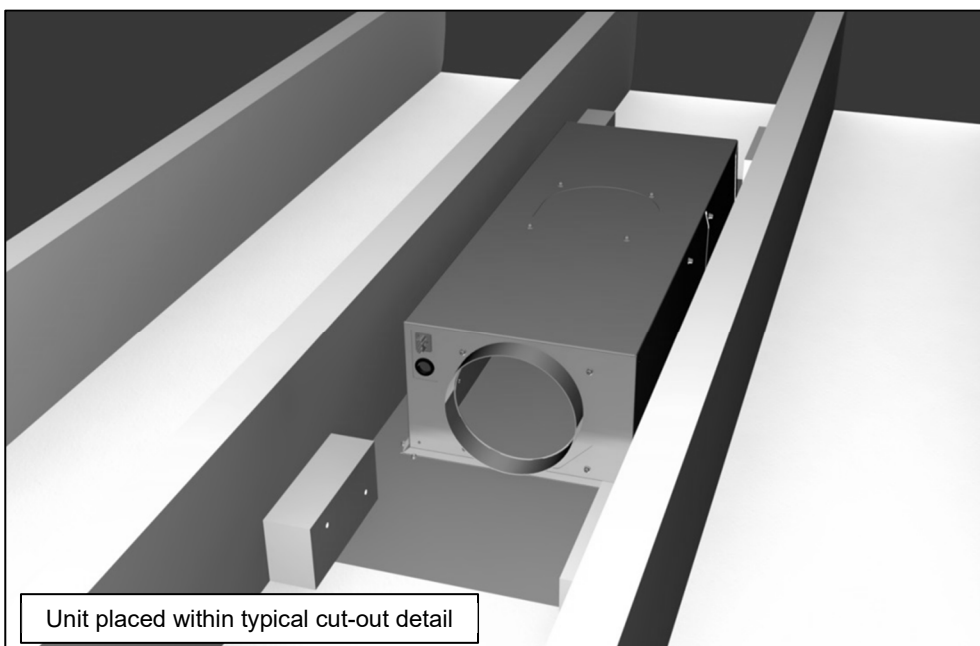
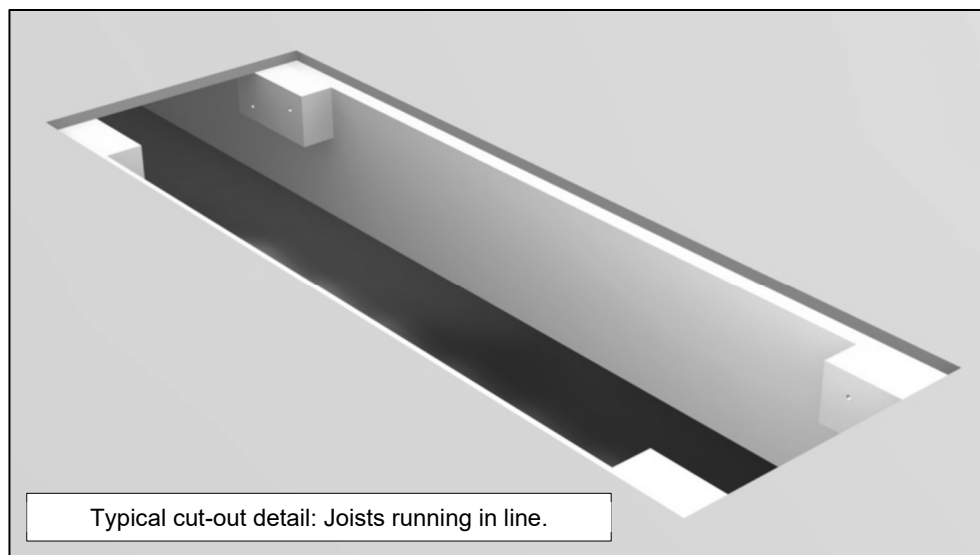
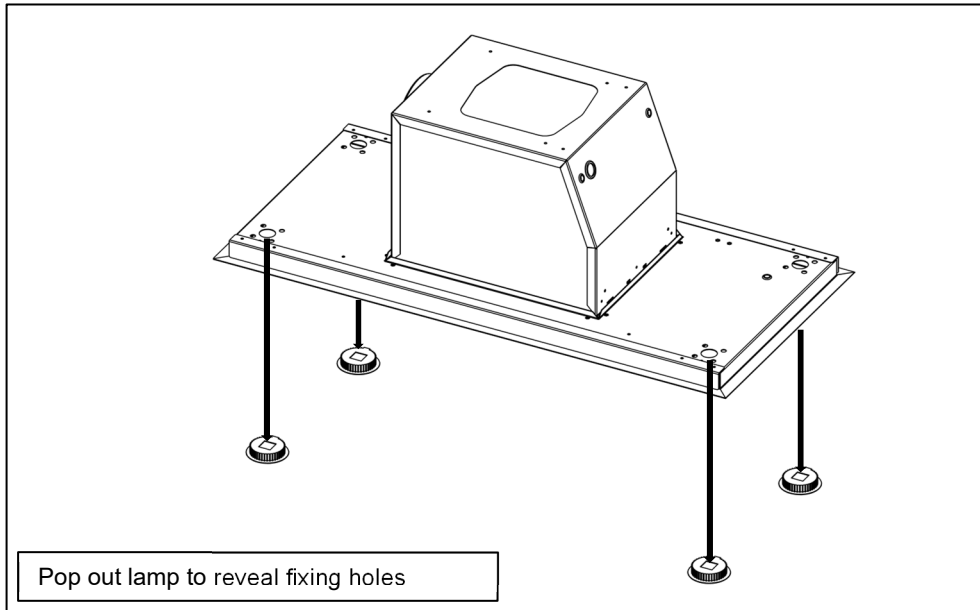

Ceiling Built-in Unit STRATUS Installation, Operating & Maintenance Instructions



7. SEM EL REMOTE MOTOR ILLUSTRATIONS

The wiring illustrations below apply to SEM EL Motors only.

The below diagram shows a typical SEM EL wiring schematic. the appliance is supplied with an external terminal box that requires connecting to the external motor.

In order to access the electrical terminals, remove the fixing screws from the external terminal box lid. Refer to fig. 2 & 3 for details of how to wire the SEM 1/2 or SEM 7/8 correctly.

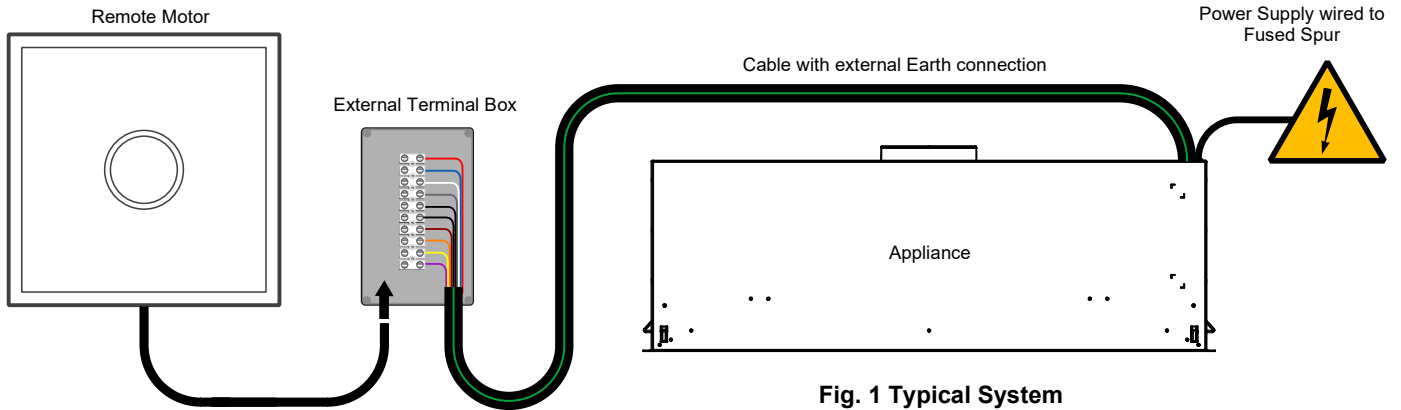

Fig. 1 Typical System

Fig. 2 Terminal Colour Positions

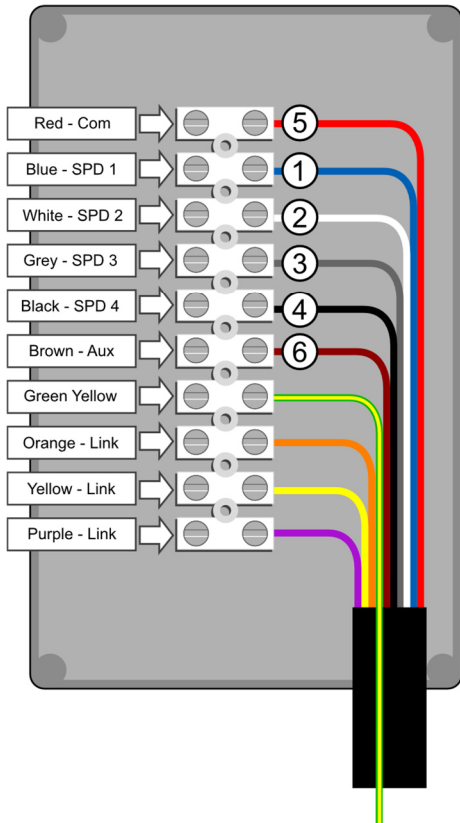
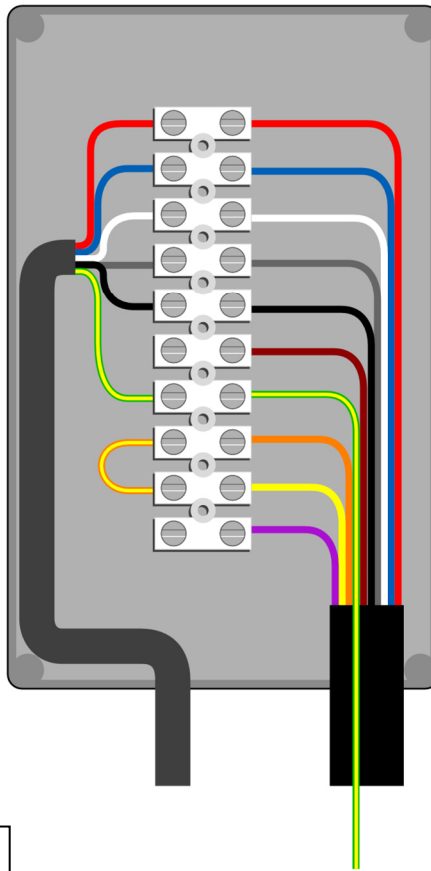
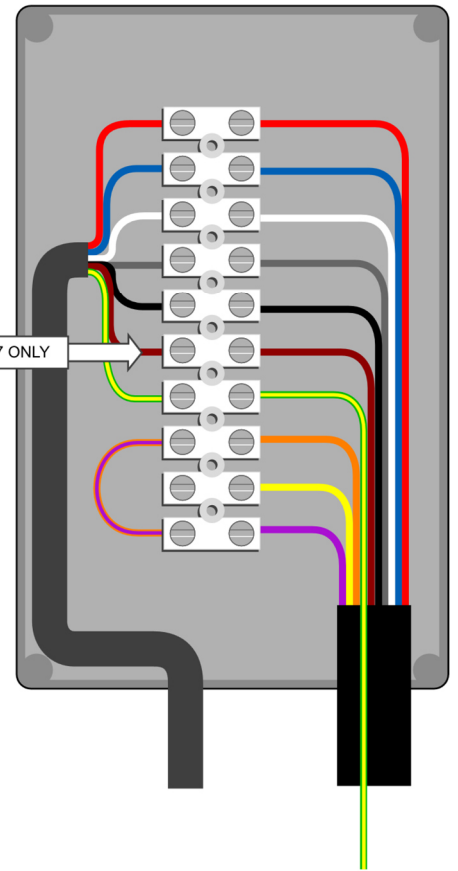

Fig. 3 SEM 1 / SEM 2
Electrical Connections



Remote Motor Cable Assembly
Orange/Yellow link wire is included

Fig. 4 SEM 7 / SEM 8
Electrical Connections



Remote Motor Cable Assembly
(Orange/Purple link wire is included)

Note:
CHECK: COLOUR SEQUENCE MAY VARY
Link terminals determine intensive speed run times, which are motor type dependent.
Aux terminal powers auxiliary PCB in some motors.

**Ceiling Built-in Unit
STRATUS
Installation, Operating & Maintenance Instructions**



STANDARD GUARANTEE CONDITIONS

Westin Ltd undertakes that if within 24 months of the date of delivery this product or any part thereof is proved to be defective by reason only of the faulty workmanship or materials, the company will, at our option, repair or replace the same FREE OF ANY CHARGE for labour, materials or carriage on condition that:

1. The product has been correctly installed and used only on the electrical supply stated on the rating plate.
2. The product has been used for normal domestic purpose only, and in accordance with the manufacturer's operating and maintenance instructions.
3. The product has not been serviced, maintained, repaired, taken apart or tampered with by any person not authorised by us.

EXCLUSIONS

This Guarantee does not cover:

- Damage or calls resulting from incorrect installation, transportation, improper use or neglect, the replacement of any light bulbs or removable parts of glass or plastic.
- Costs incurred for calls to put right appliances improperly installed or calls to appliances outside the United Kingdom.
- Normal wear and tear.
- Products deemed to be in use within a commercial environment.
- Grease filter mesh.
- Bulbs and LEDs.
- Consumables.
- Damage caused to the body by usage of detergent sprayer or other contaminants.
- Damage or corrosion of the LED parts, glass parts and stainless-steel parts.
- Damage caused by foreign objects or accident.
- Any products taken apart or serviced by unauthorised individuals or service engineers or replaced with other manufacturer's components.
- Product not installed with the correct size ducting as stated in the manual.

This Guarantee is in addition to your statutory and legal rights.

Please see our website www.westin.co.uk for details of our Conditions of Sale and to register your guarantee.