



# WESTIN

## PRIME EDGE

### Built-in Unit

#### Installation, Operation and Maintenance

INTRODUCTION	2
IMPORTANT INFORMATION	2
EXTRACTION PERFORMANCE	2
INSTALLATION	3
SPECIFICATIONS	7
DRAWINGS & ILLUSTRATIONS	8
OPERATING INSTRUCTIONS	9
MAINTENANCE	12
GUARANTEE	13

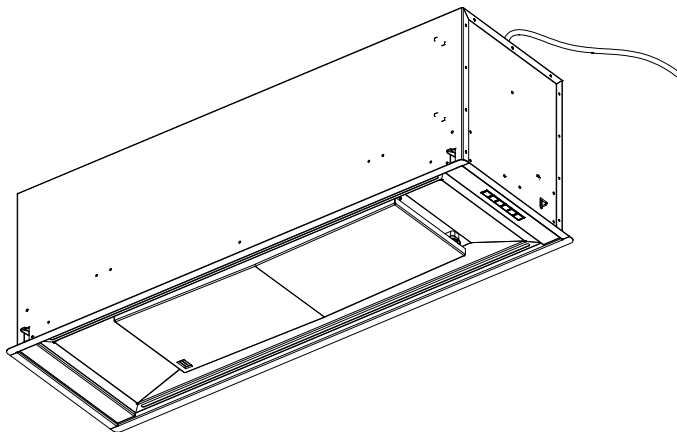

#### Unpacking

Remove all items from the packaging. Retain the packaging.  
If items are missing or damaged, please contact Westin for assistance.



# Prime EDGE 800 - 1100 Built-in Extractor

## Installation, Operating & Maintenance Instructions

### 1. INTRODUCTION

During the cooking process, there will be heat, vapours and fumes produced. Your Westin built-in extractor has been designed to complement your kitchen both in looks and performance in order to create a good environment for creative cooking and is ideal for applications where a conventional cooker hood is neither suitable nor desirable (in an inglenook chimney or kitchen furniture above the hob for example).

### 2. IMPORTANT INFORMATION

The exhaust air **must not** be discharged into a flue which is used for exhausting fumes from non-electric appliances such as oil or gas-fired central heating boilers or gas-fired water heaters, etc.

Requirements of the relevant authorities concerning the discharge of exhaust air must be complied with.

Pay particular attention to fire risk when frying. To minimise the risk of fire, all instructions relating to cleaning the grease filters and removing grease deposits must be adhered to.

Do not flambé under the extractor.

#### WARNING

Proper care must be taken to ensure that the negative pressures caused by high performance extraction systems do not adversely affect the safe operation of certain types of fuel-burning appliances (gas, oil or solid fuel), including those installed in the kitchen and possibly those installed in other parts of the house.

Where such fuel-burning appliances are installed, adequate ventilation **MUST** be provided in the room of installation, located and sized such that the negative pressure in the room created by the extractor does not exceed 4Pa.

In case of doubt, do not operate the extractor and fuel-burning appliance(s) simultaneously and consult an appropriate (for the fuel type) expert for advice.

#### ELECTRICAL SAFETY

This appliance requires an earth connection.

Ensure that the supply voltage corresponds to that marked on the rating label inside the extractor.

The extractor must be isolated from the electrical supply before carrying out any cleaning or maintenance operations.

**The clearance between the hob burners and the bottom surface of the cooker hood (extractor) should be within the following range, unless a greater distance is specified by the cooking appliance manufacturer:**

#### Hob to underside of the cooker hood clearance distances:

- 550mm Minimum above electric hobs (650mm recommended).
- 760mm Minimum above all gas hobs and gas or electric wok burners, griddles, fryers, open grills / barbeques.
- 800mm is the maximum recommended distance between the hob and underside of the cooker hood.

The minimum distance between the hob and the bottom of the extractor is essential for safety reasons and to prevent overheating of the extractor and its components.

Exceeding the maximum clearance distance will reduce how efficiently the cooker hood removes cooking fumes and odours.

Please also note that a 90° bend in 150mm flexible ducting will require 215mm minimum headroom to give a smooth radius with no kinking.

**You are advised to install measures designed to reduce the incidence of cold draughts entering the property via any ductwork.**

For extractors with internal or inline motors, this should, at the very least, consist of an external duct termination with integrated non-return flaps (e.g. gravity shutter wall grille/louvre) and/or an inline backdraught shutter.

For wall-mounted motors, an inline backdraught shutter is recommended.

### 3. EXTRACTION PERFORMANCE

The primary influence on the overall performance of the extractor is the design of the ducting which takes the exhaust air from the extractor to the outside. The duct route should be a prime consideration during the initial stages of the kitchen design (*Westin* do not recommend recirculating air back into the kitchen).

#### Please note the following:

- Easy access to the duct route during installation is important. Lack of access may require the "blind" fitting of flexible ducting, with increased risk of unseen kinks and impaired efficiency.
- **The extractor is provided with a spigot(s) suitable for connecting 150mm round ducting (or equivalent cross section). Ducting must not be reduced.**  
**Note: Failure to adequately fit the ducting stated above will void your written Guarantee under the Standard Guarantee conditions.**
- The most efficient configuration is to duct straight through an outside wall so try to position the cooker against an outside wall when designing your kitchen.
- Well installed, correctly sized rigid round ducting (or an equivalent flat channel system) will usually perform best, with round semi-rigid ducting as an alternative. Flexible (foil or plastic film) ducting is economical but its use should be minimised as it gives the worst performance and should only be used for very short duct runs or initial connection and should be pulled taut to prevent significant losses in extraction efficiency.
- For maximum efficiency, ducting should be kept as short and as straight as possible. Bends in the duct will degrade performance so the number of bends in a duct run should be kept to a minimum and be gradual and smooth to prevent turbulence. Avoid kinks in flexible ducting and pull the ducting taut over straight runs to ensure that the internal surface is as smooth as possible.
- If using rigid ducting, we recommend that the initial duct connection to the extractor spigot is made using semi-rigid round ducting to allow for any positioning errors and easy disconnection in the event of maintenance.
- Ducting and associated components (including complete kits) are available from *Westin*.

### 4. INSTALLATION

**This document provides detailed guidance for a typical installation, however not all installations can be accommodated within this guide.**

**If you are unsure how to proceed then please call Westin for assistance.**



# Prime EDGE 800 - 1100 Built-in Extractor Installation, Operating & Maintenance Instructions

To install the hood, it is necessary to remove the baseplate and filters to gain access to fixing holes & duct spigot(s).

Open the appliance door by pulling from the front to release the magnets. The door is hinged to reveal the filter(s). Remove the filter(s) (as described in section 6).

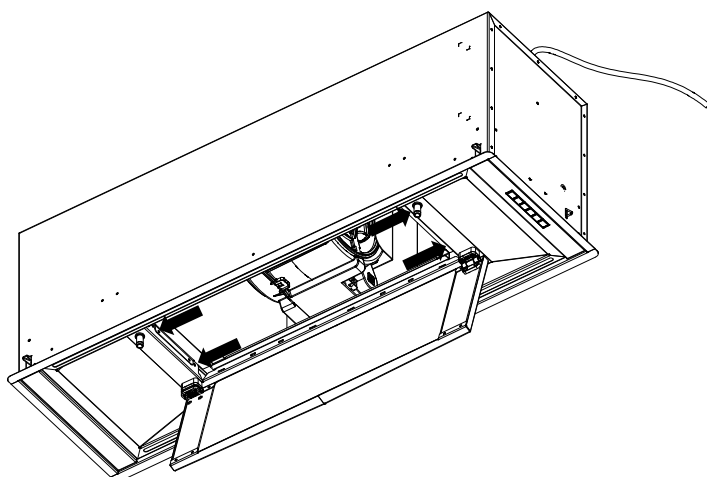

Once the filter has been removed, locate the 4 fixing screws that retain the base plate (see above illustration). Separate the baseplate by pulling the panel assembly away from the rest of the appliance.

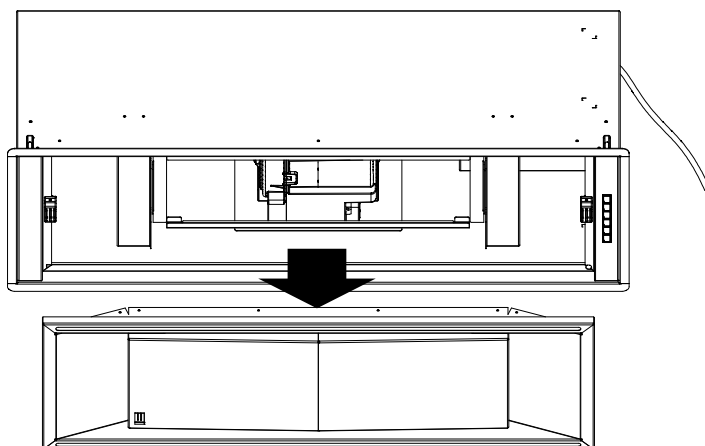

The PRIME EDGE range of built in extractors are designed to slot into a cut-out/opening made in a horizontal soffit panel (usually the underside of kitchen furniture or inglenooks / chimney arrangements).

**The soffit panel into which the unit is to be fixed must be between 15mm and 22mm thick.**

### Prepare Opening

Prepare an opening where the extractor is to be installed. Detailed dimensioned drawings showing the extractor layout can be found in Section 6 "General Arrangements Drawings" to help you with this.

### Duct Installation

Make holes as necessary, in the walls or ceiling to take the ducting from the exhaust spigot location to the outside.

**Note:** We recommend oversizing your duct holes by 25mm to allow for any cables that may need to run alongside the duct (such as remote motor or power cables) and for the easy installation of your ducting in general.

Depending upon your installation you may need to run the ducting before or after the extractor is in place, however, all holes must be made in advance to avoid debris entering the appliance.

The duct route length should be kept as short as possible with as few bends as possible (see Section 3).

If terminating on an outside wall, a suitable weather louvre should be fitted. A variety of ducting components and complete kits are available from *Westin* to suit most installations.

For roof or chimney duct terminations, please contact *Westin* or seek alternative specialist advice.

### Recirculating Models

*Westin* do not recommend recirculating air installations and they should be avoided wherever possible (see section 3).

If your extractor has been adapted for recirculation, (not our standard configuration) then adequate provision must be made for exhausted air to return into the kitchen (equivalent to 150mm round duct) - e.g. ducted out through the top of the cabinet. Failure to do so may cause the unit to overheat and fail and will invalidate your warranty.

### Remote Motors

If your extractor has been purchased to operate with a standard inline or external remote motor (SEM), then you will find a black plastic box outside the extractor (on flying leads) containing electrical terminals for connection to the remote motor cable assembly. This box is referred to as the remote motor terminal box.

Each terminal inside the remote motor terminal box has one side connected to a coloured wire, which leads back to the hood control system. The remote motor cable assembly also has coloured wires and these are connected to the empty terminals. Such corresponding colours are opposite and connect to each other; i.e. red connects to red, blue to blue, and so on.

Not all terminals will be used as each remote motor type is configured differently.

An electrician (or Part P registered electrical installer) should undertake any work associated with the electrical installation of SEM remote motors.

**Please refer to 6.1 REMOTE MOTOR ILLUSTRATIONS for more information.**

If you need to extend the remote motor cable, then additional cable can be purchased from *Westin*. Alternatively, it may be extended using 7 core x 0.5mm flex. It is vital to ensure that any new cable is inserted such that the core colour integrity is maintained; i.e. a core that started as red must terminate as red, blue as blue, purple as purple, and so on.

Any remote motor should be installed in accordance with the installation instructions that accompany it. It must be installed in an easily accessible location for future maintenance. *Westin* are not responsible for providing the means of access (e.g. scaffolding or any alterations to the building and/or furniture necessary to make access possible) in the event of any maintenance requirement.

No separate power supply is required for SEM remote motors.

### Electrical Supply

**ELECTRICAL HAZARD.  
DISCONNECT ELECTRICAL SUPPLY BEFORE  
PROCEEDING FURTHER**

## Prime EDGE 800 - 1100 Built-in Extractor

### Installation, Operating & Maintenance Instructions

The extractor is a stationary appliance supplied with an electrical supply flex and moulded 3 pin UK plug (3A) for connection to the electrical supply.

**The appliance must be fed from a 230Vac single phase electrical supply.** You may wish to terminate the electrical supply using a standard mains electrical socket positioned close to the extractors intended location.

Alternatively, you may terminate the electrical supply from a switched-fused spur. The spur should be located adjacent to the hood/cooker so that the supply can be disconnected from the hood using the switch. The means of disconnection from the supply must have a minimum contact separation of 3mm in all poles. A competent Part P registered electrical technician must perform the electrical installation.

The mains supply is connected as follows:

INCOMING SUPPLY CORD CONNECTIONS	
Core	Core Colour
Live	Brown
Neutral	Blue
Protective Earth	Green/Yellow

#### Connecting the Ducting

Terminate the ducting where it exits the building. If using a wall mount weather louvre, secure the ducting to the louvre spigot and attach the louvre to the wall. Ensure that the air fins are directed downwards. If you are fitting an alternative termination, ensure that the ducting is secure.

If using expanding foam, make sure that any flexible ducting is supported internally to prevent it crushing where foamed.

Pull flexible ducting back along its route to ensure that it is as smooth as possible.

Note: Internal motor models have non-return flaps as part of the spigot assembly to reduce air blowing back into the unit from outside. For remote motors, air ingress can be limited by your choice of ducting components. Take care not to obstruct any backdraught flaps when connecting flexible ducting.

#### Top outlet and side outlet (left or right) models only

Position the extractor face down (and as close to the opening as is practical) and cut off excess before connecting the ducting to the extractor exhaust spigot using plastic tie straps or a suitable alternative (e.g. jubilee clip) - **do not use duct tape as the sole means of connection.**

#### Rear outlet models only

Note: If a bend can be accommodated, then the Top Outlet model is always desirable due to the reduced installation complexity.

If a Rear Outlet Model must be installed, then the duct cannot be attached prior to installation because the duct spigot protrudes from the rear and prevents the insertion of the extractor into the prepared opening.

Instead, the blower and spigot plate assembly must be separated from the extractor and pulled back inside the appliance. 4 nuts secure the rear exit blower plate to studs on the rear of the extractor. These are accessible through the filter openings and will need to be removed so that the blower assembly can be pulled back into the extractor body prior to installation.

Once the hood has been installed, flexible duct can then be pulled into the extractor and attached to the duct spigot prior to refitting the blower assembly. To ease installation, you may wish to use a rigid duct instead, which, providing the duct route and spigot are properly aligned, can be pushed onto the spigot from behind/outside after the hood is in position.

#### Fixing the Extractor in Position

- Fixing the extractor safely into position requires two people so do not start if assistance is unavailable.
- *For Rear Outlet Models Only:* separate the blower assembly from the rear of the appliance (as described in 4.5) and pull it back into the extractor so that the duct spigot no longer protrudes from the hood rear.
- The extractor is held securely in place by 4 adjustable spring toggles (only visible on the outer casing of the unit).
- Screws for adjusting the height of each spring toggle are located behind the grease filters on the outer filter housing flange (see Fig 1). The spring toggles are moved up by turning the screws anti-clockwise and down by turning the screws clockwise.
- Ensure that each spring toggle height is set such that when pushed from outside it moves freely and fully into the outer casing of the unit and when slowly released returns to an open position just below the top of the spring toggle slot. The spring toggle should protrude from the casing by at least 8mm (see Fig 1).

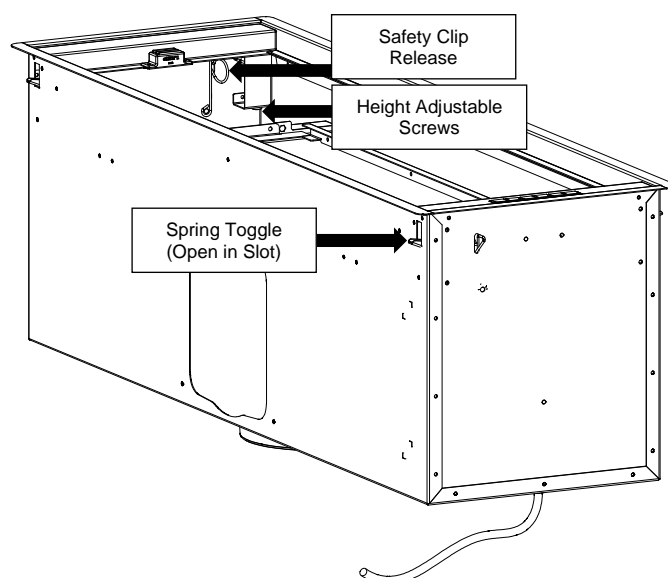

- Supplementary support of the unit is provided by sprung safety clips which are intended to hold the unit safely in place during removal (see later). The safety clips (Fig 1) should be disabled for installation by pulling the clip release into the body until the clip latch is clear of its slot and then sliding to one side so that the clip latch rests against the inner casing of the unit.
- Check that the electrical supply cord (and any remote motors) have been connected, that power is switched off and the ducting is securely fastened to the spigot.
- Push the extractor up through the prepared opening until the spring toggles are heard to snap over the edge of the opening – we recommend that two people do this (supporting one end of the extractor each). Carefully release the unit, ensuring that it is supported within the opening by all four spring toggles. If a spring toggle fails to catch, try pushing upwards again and if this fails remove the unit as described later and check the panel thickness and setting of the spring toggles as described earlier.
- Re-enable the two sprung safety clips by once again pulling the safety clip release (Fig 1.) and sliding the clip latch back into the slot from which it was earlier withdrawn. The clip latch should pass fully through the outer casing.



# Prime EDGE 800 - 1100 Built-in Extractor Installation, Operating & Maintenance Instructions

- Close up any gaps between the soffit panel and the units outer flange (often referred to as the fixing flange) by turning the spring toggle adjustment screws clockwise. If the gap is larger than 1-2mm, then this should be done in stages, working your way around each adjustment screw in turn until the unit has been pulled up into position.
- *For Rear Outlet Models Only:* working through the filter opening, connect the ducting to the blower spigot and refit the blower assembly to the rear panel of the extractor (using the nuts and washers you removed earlier). Note, if using rigid ducting, providing the duct route and spigot are properly aligned, it may be easier to push ducting onto the spigot from behind/outside after the blower is refitted.

Note: Consider whether it is possible to build in provisions for accessing the ducting with the unit in place - this may simplify installation and enable easier straightening of the duct, inspection and removal.

### Removing the Motor Transport Ties (If Fitted – See Fig.2)

Note: Transport Ties are only used on smaller appliances to protect the motor during unpalletised transit.

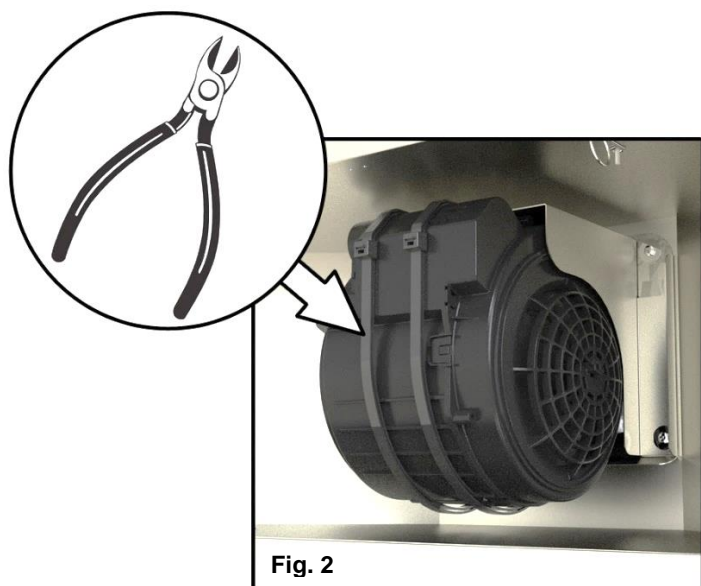

### Removing the Extractor

- First remove the grease filters and ensure that the sprung safety clip is correctly set. Only the clip release hoop and mounting arm should be on the inside of the unit with the rest of the clip fully through the slot in the extractor casing (as in Fig 1). If in doubt, pull the clip release to reveal the clip latch and make sure that it passes fully back through the casing when released.
- With the safety clips correctly set, turn the spring toggle height adjustment screws anti-clockwise. The extractor will gradually start to lower. This is best done in stages, working your way around the 4 screws, thus lowering the unit evenly and avoiding undue stress on any one spring toggle.

Note: as you turn the adjustment screws, the spring toggles gradually rise until they reach the top of their slots, after which, they start to retract into the extractor casing.

You will know when the spring toggles start to retract because the extractor will start to rise up into the soffit rather than lower. When this happens, you should support the extractor and continue to turn the screws carefully clockwise. When the spring toggles have retracted sufficiently, the unit may drop if not supported.

- The sprung safety clips are there to catch the unit and to prevent it falling from the opening in the soffit. Lower the

extractor carefully until the safety clips are supporting it - if the opening has not been correctly prepared then the safety clips may not catch on the edge of the opening, so be prepared to continue lowering the unit down and out of the opening.

- **Two people** are required to lower the unit safely.

The unit is released for final lowering by each person pulling the safety clip release back into the extractor (whilst also supporting the unit), thus disengaging the unit from the soffit.

### 5. SPECIFICATIONS

All Models	
Supply Voltage:	230V~ 50Hz
Lighting: 12V 15W LED (Per Strip):	12V, 30W
Extractor Duct Spigot Diameter:	150mm
<b>Total power:</b>	<b>See rating plate</b>

Internal Motor Specifications	
Airflow, nominal in free air:	800 m <sup>3</sup> /hr
Power input:	275W
Duct Spigot diameter:	150mm

SEM1 EL Inline Duct Motor Specifications	
Airflow, nominal in free air:	800 m <sup>3</sup> /hr
Power input:	275W
Duct Spigot diameter:	150mm

SEM2 EL Wall Mounted Motor Specifications	
Airflow, nominal in free air:	900 m <sup>3</sup> /hr
Power input:	200W
Duct Spigot diameter:	150mm

SEM7 EL Wall Mounted Motor specifications	
Airflow, nominal in free air: 200mm Dia Duct	1,700 m <sup>3</sup> /hr
Airflow, in free air via supplied 150mm reducer	1,500 m <sup>3</sup> /hr
Power input:	490W
Duct Spigot diameter:	200/150mm
<i>Note: The motor has a 200mm diameter spigot and is supplied with a reducer for connection to 150mm ducting.</i>	

SEM8 EL Inline Motor specifications	
Airflow, nominal in free air: 200mm Dia Duct	1,300 m <sup>3</sup> /hr
Airflow, in free air via supplied 150mm reducer	1,100 m <sup>3</sup> /hr
Power input:	250W
Duct Spigot diameter:	200/150mm
<i>Note: The motor has a 200mm diameter spigot and is supplied with a reducer for connection to 150mm ducting.</i>	

Recommended Protective Fuse Sizes for Electrical Supply	
Models installed with:	3A
Internal Motor	
SEM 1 Inline Fan	
SEM 2 Wall Mounted Fan	
SEM 7 Wall Mounted Fan	
SEM 8 Inline Fan	

*Note: For more detailed specification and energy efficiency information please refer to the product fiche for your product.*

### Main Reset Switch

The Reset Switch is a red rectangular switch located inside the extractor. The Switch can be accessed by opening the Door and removing the Filter. Press the Reset Switch to unlatch 'out'. Press the Reset Switch again to relatch 'in'. The Switch must be in the latched 'in' position in order for the extractor to operate.

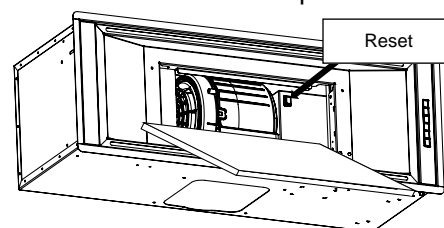



# Prime EDGE 800 - 1100 Built-in Extractor

Installation, Operating & Maintenance Instructions

## 6. GENERAL ARRANGEMENT DRAWINGS

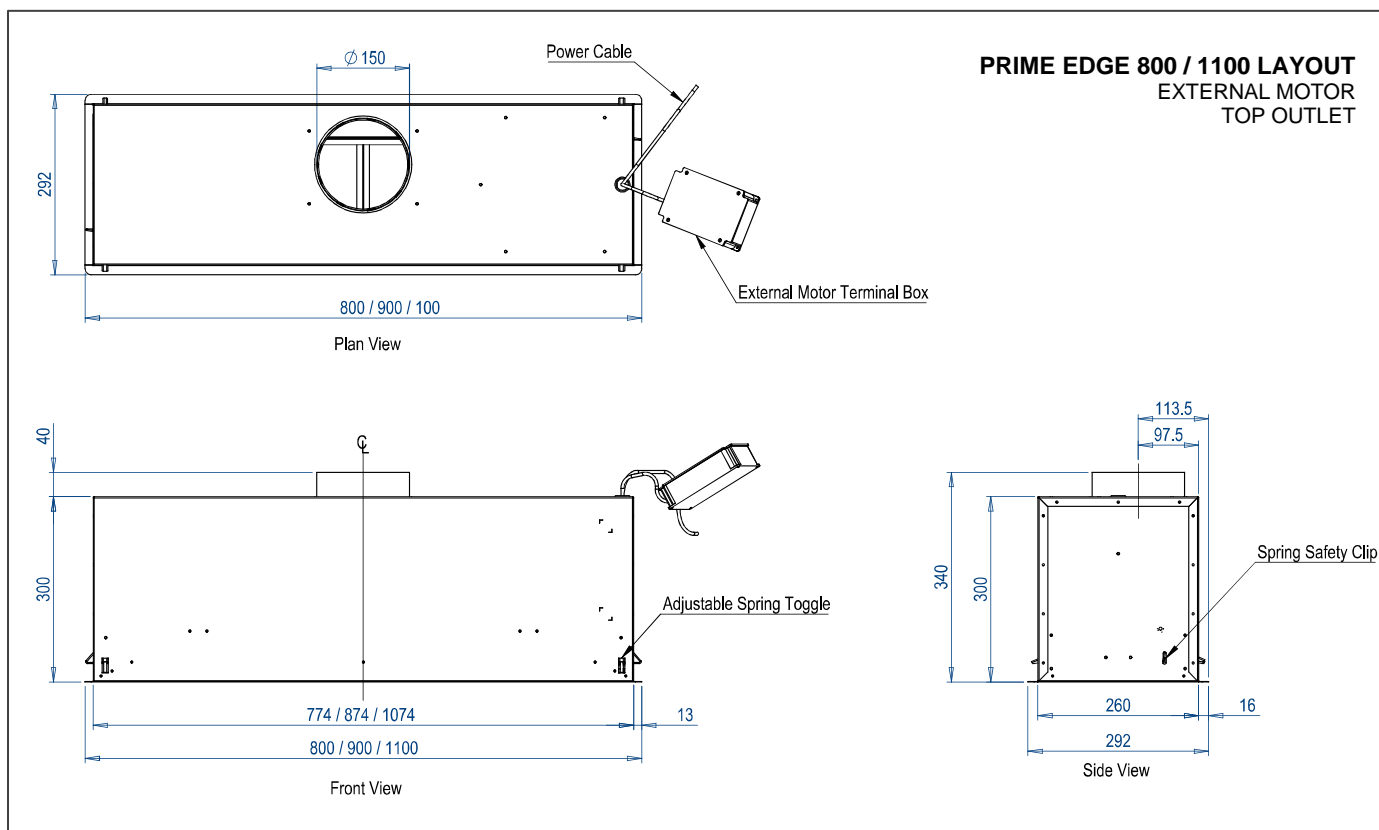
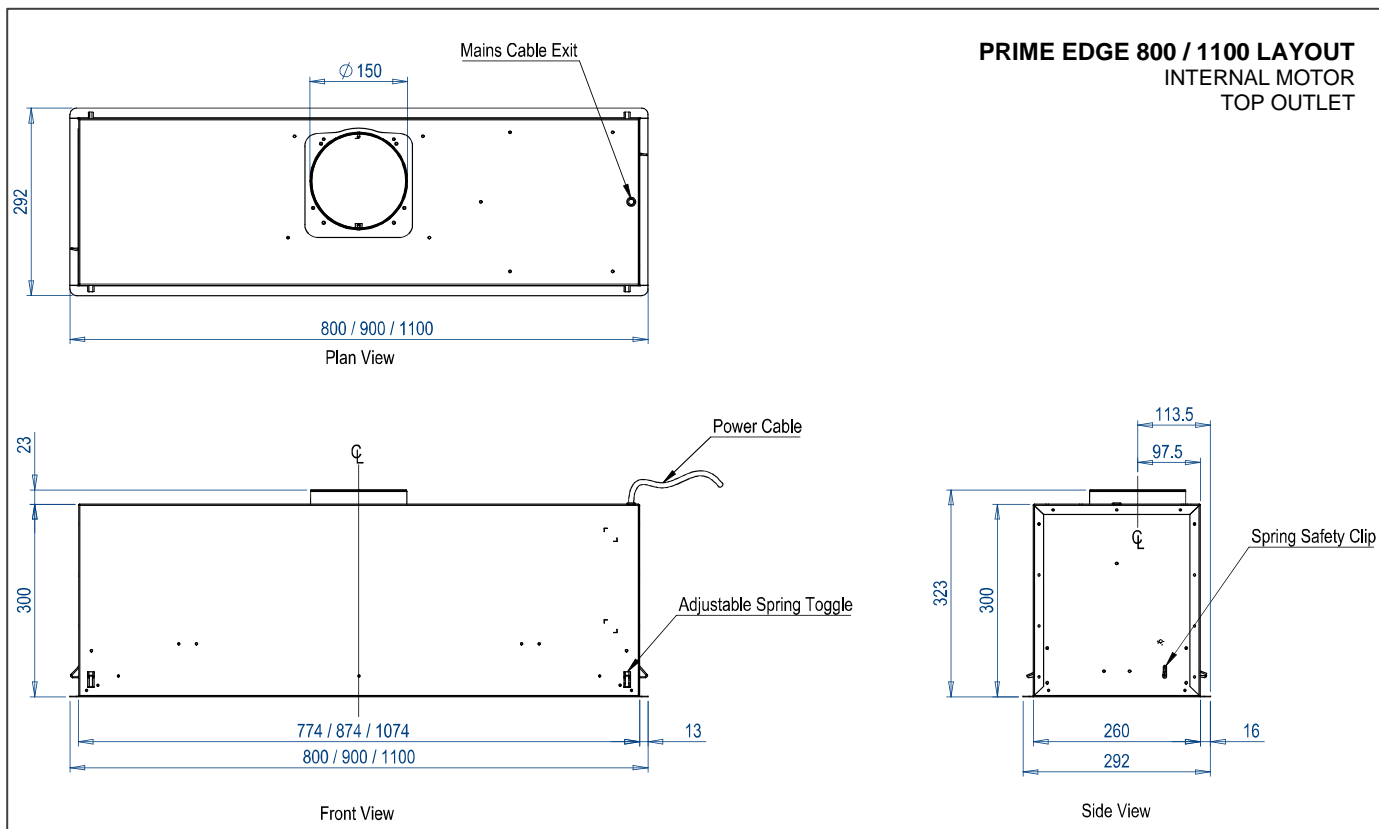



# Prime EDGE 800 - 1100 Built-in Extractor Installation, Operating & Maintenance Instructions

## PRIME EDGE 800 / 1100 LAYOUT INTERNAL MOTOR REAR OUTLET

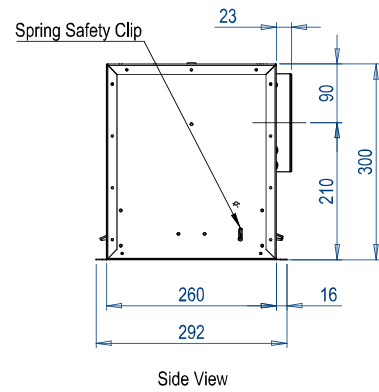
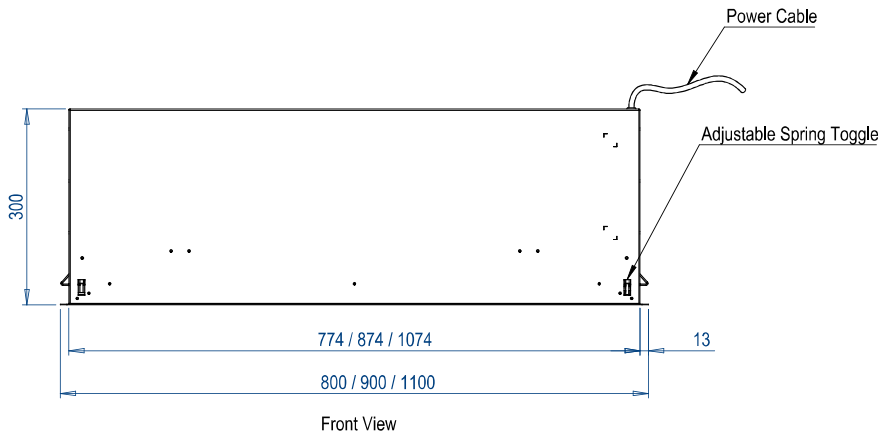
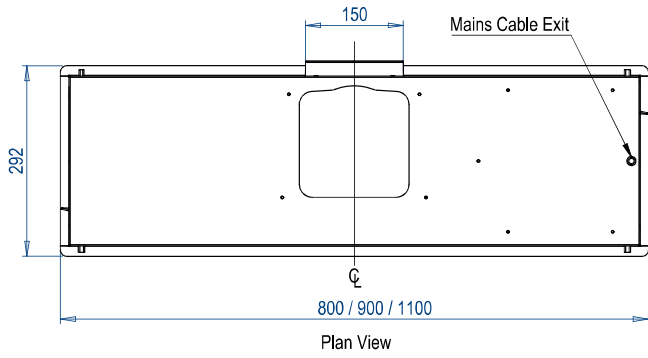

## PRIME EDGE 900 / 1100 LAYOUT EXTERNAL MOTOR REAR OUTLET

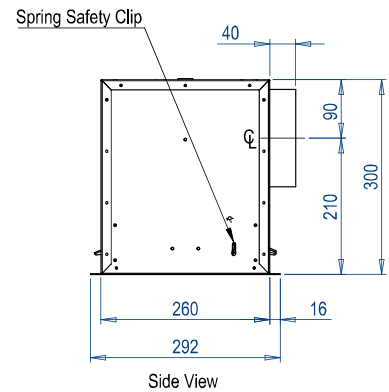
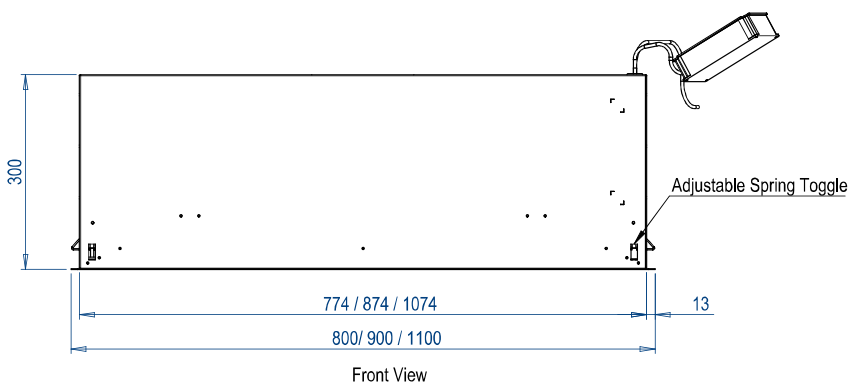
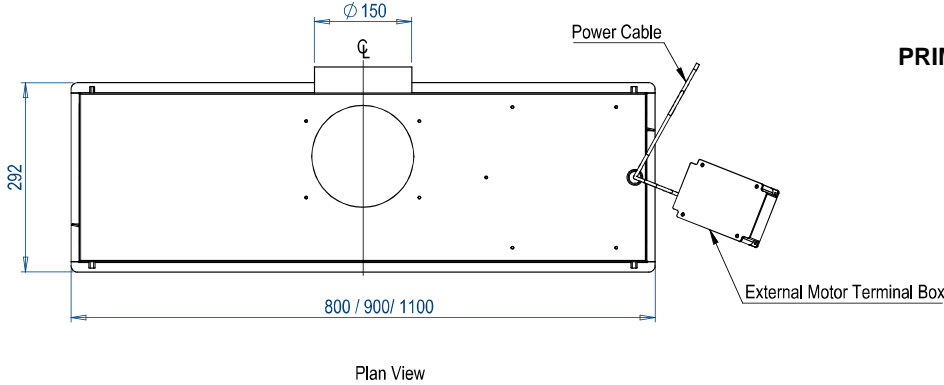



# Prime EDGE 800 - 1100 Built-in Extractor

## Installation, Operating & Maintenance Instructions

**WESTIN**

### PRIME EDGE 800 / 1100 LAYOUT INTERNAL MOTOR EXPLODED PARTS LIST

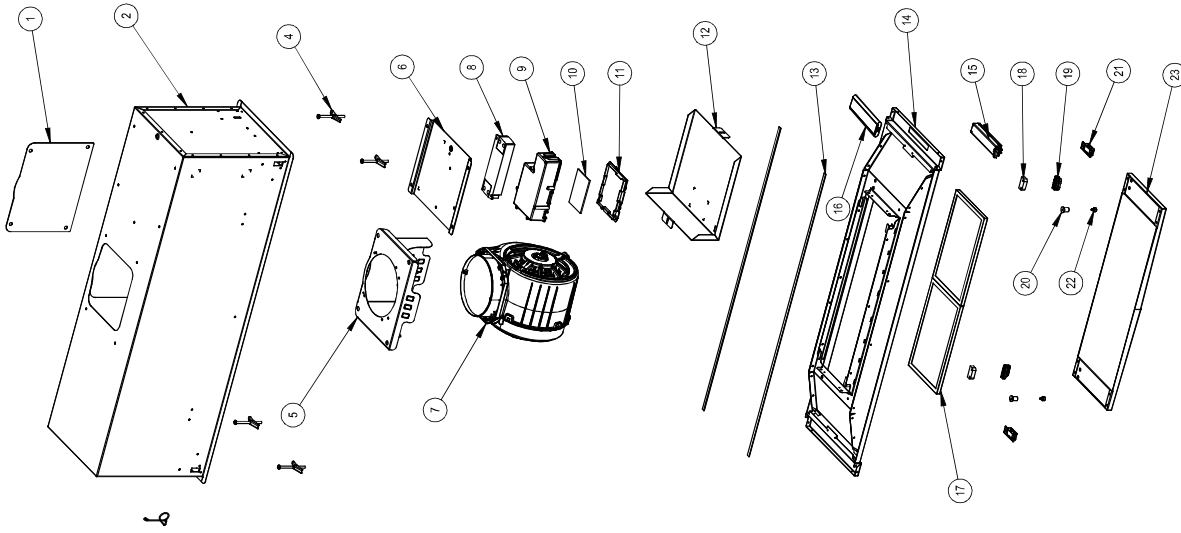

No	Part Name	Part Number	Notes and Special Ordering Instructions
1	Blank Plate	Made to Order	
2	Extractor Body	Made to Order	State hood width
3	Spring Safety Clip	W0803	
4	Adjustable Spring Toggle	W0801 - W0802	
5	Motor Bracket	Made to Order	
6	Control Box Base	Made to Order	
7	Motor	*W1437	
8	LED Driver	W1389	
9	Circuit Board Housing	*W0419 - *W0421 - *W0422	
10	Circuit Board	*W1836	
11	Circuit Board Housing Lid	*W0420	
12	Control Box Lid	Made to Order	
13	LED Strip Lights	W1792 for 900 Wide Version W1793 for 1100 Wide Version	
14	Extractor Baseplate	Made to Order	State hood width
15	Pushbutton Controls	W1741	
16	Remote Control	W1798	
17	Grease Filters	W0777	
18	Hinge Spacer	W1796	
19	Hinge	W1780	
20	Magnet Post	W1795	
21	BP Support Magnet	W1758	
22	Magnet for Post	W1782	
23	Door Panel	WSW - CACHE EDGE 900 DOOR - SS for 900 Wide WSW - CACHE EDGE 1100 DOOR - SS for 1100 Wide	
	Internal Motor Assembly	W1788	* Part numbers included with motor assembly

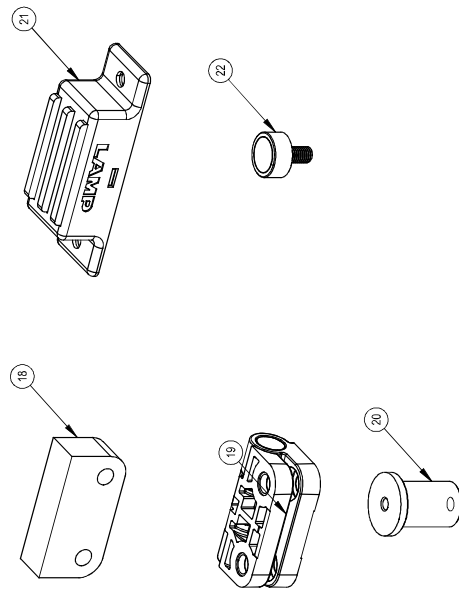



# Prime EDGE 800 - 1100 Built-in Extractor

## Installation, Operating & Maintenance Instructions

**WESTIN**

### PRIME EDGE 800 / 1100 LAYOUT EXTERNAL MOTOR EXPLODED PARTS LIST

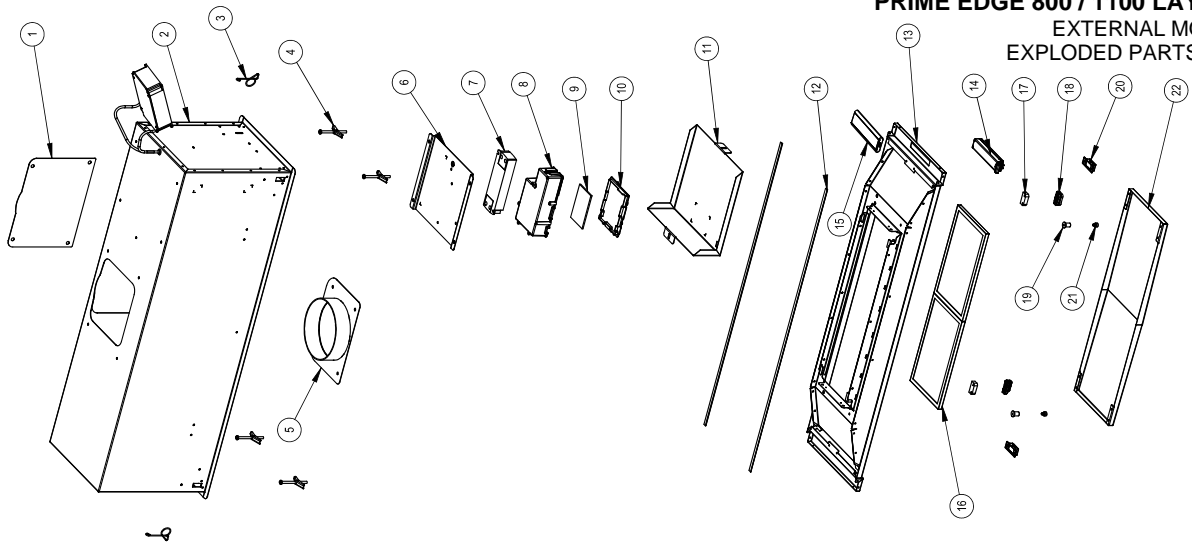

No	Part Name	Part Number	Notes and Special Ordering Instructions
1	Blank Plate	Made to Order	
2	Extractor Body	Made to Order	State hood width
3	Spring Safety Clip	W0803	
4	Adjustable Spring Toggle	W0801 - W0802	
5	Spigot Plate	Made to Order	
6	Control Box Base	Made to Order	
7	LED Driver	W1389	
8	Circuit Board Housing	*W0419 - *W0421 - *W0422	
9	Circuit Board	*W1836	
10	Circuit Board Housing Lid	*W0420	
11	Control Box Lid	Made to Order	
12	LED Strip Lights	W1792 for 900 Wide Version W1793 for 1100 Wide Version	
13	Extractor Baseplate	Made to Order	State hood width
14	Pushbutton Controls	W1741	
15	Remote Control	W1798	
16	Grease Filters	W0777	
17	Hinge Spacer	W1796	
18	Hinge	W1780	
19	Magnet Post	W1795	
20	BP Support Magnet	W1758	
21	Magnet for Post	W1782	
22	Door Panel	WSW - CACHE EDGE 900 DOOR - SS for 900 Wide WSW - CACHE EDGE 1100 DOOR - SS for 1100 Wide	
	External SEM Assembly	W1789	* Part numbers included with SEM assembly

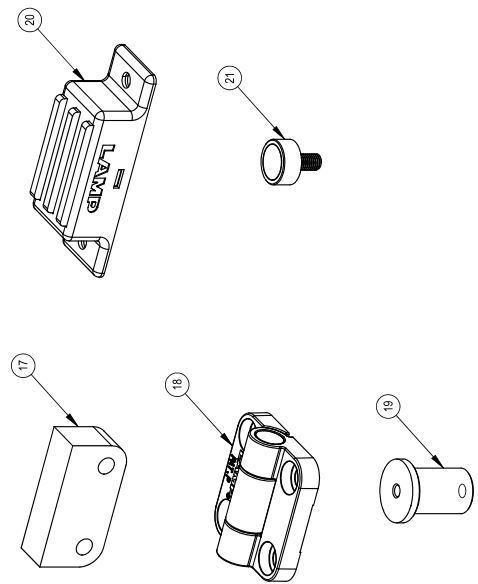

# Prime EDGE 800 - 1100 Built-in Extractor

## Installation, Operating & Maintenance Instructions

### 7. SEM EL REMOTE MOTOR ILLUSTRATIONS

The wiring illustrations below apply to SEM EL Motors only.

The below diagram shows a typical SEM EL wiring schematic. The appliance is supplied with an external terminal box that requires connecting to the external motor.

In order to access the electrical terminals, remove the fixing screws from the external terminal box lid. Refer to fig. 2 & 3 for details of how to wire the SEM 1/2 or SEM 7/8 correctly.

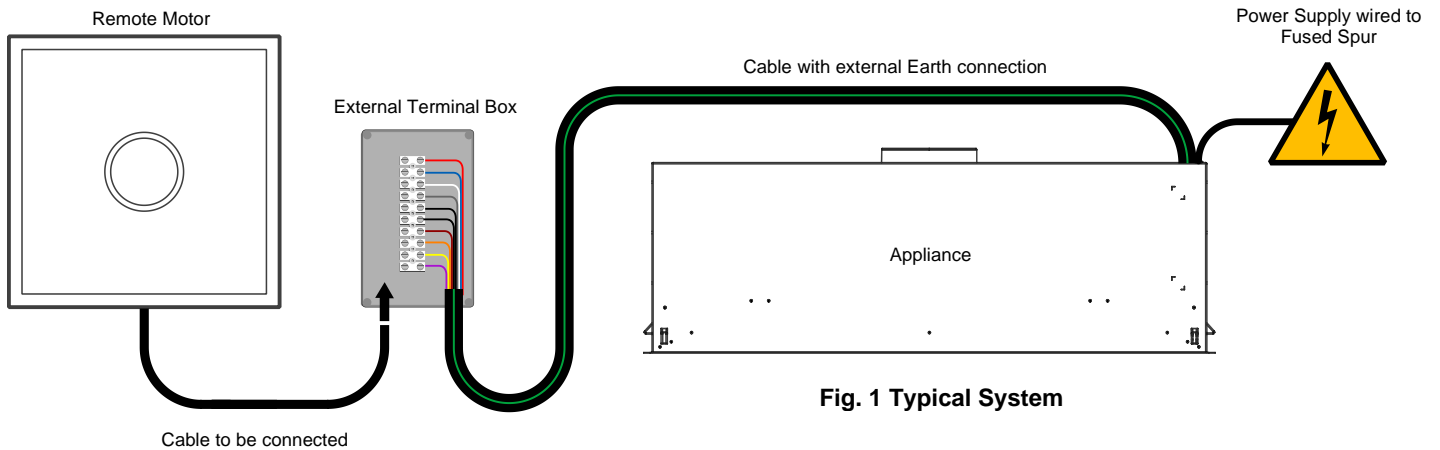

Fig. 1 Typical System

Fig. 2 Terminal Colour Positions

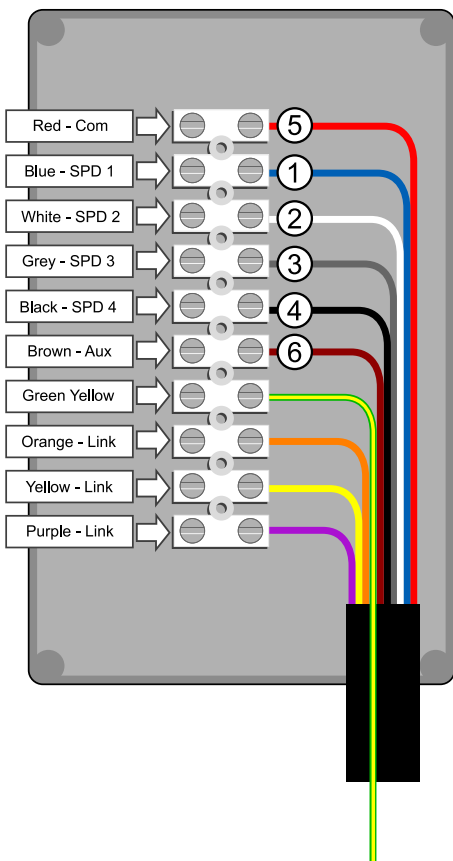

Fig. 3 SEM 1 / SEM 2 Electrical Connections

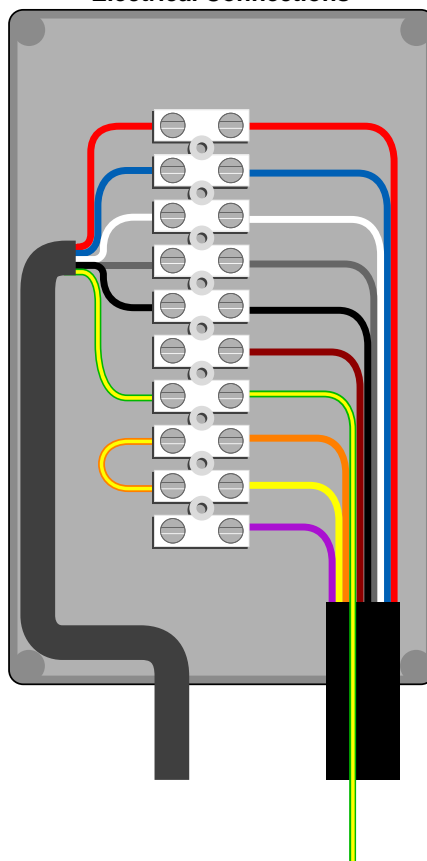
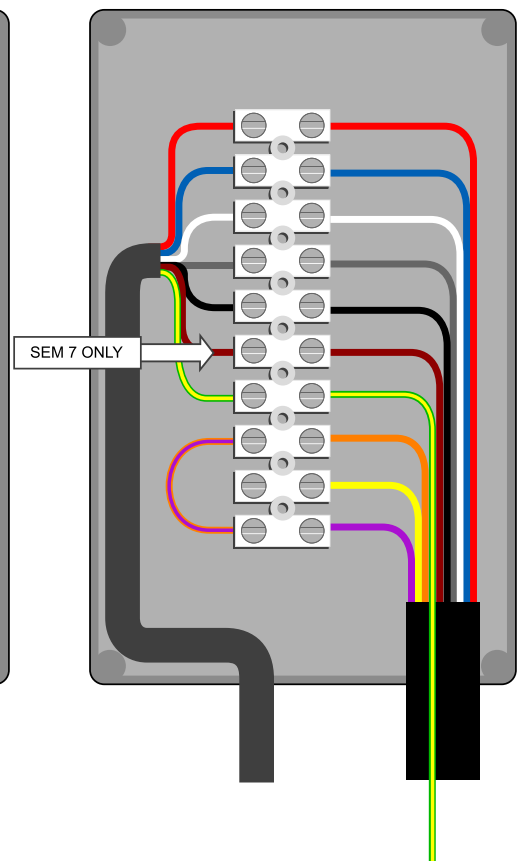

Fig. 4 SEM 7 / SEM 8 Electrical Connections



**Note:**  
**CHECK: COLOUR SEQUENCE MAY VARY**  
**Link terminals** determine intensive speed run times, which are motor type dependent.  
**Aux terminal** powers auxiliary PCB in some motors.

Remote Motor Cable Assembly  
 Orange/Yellow link wire is included

Remote Motor Cable Assembly  
 (Orange/Purple link wire is included)

# Prime EDGE 800 - 1100 Built-in Extractor

## Installation, Operating & Maintenance Instructions

### 8. OPERATING INSTRUCTIONS

Depending upon the model purchased, your extractor will be controlled via electronic pushbuttons, radio remote controller or both pushbuttons and remote controller.

Switch on the power at the fused spur.

#### Pushbutton Functions

(for models with pushbutton controls)

- ⏻ Motor RUN ON TIMER (OFF after 10 minutes)
- 4 Motor ON – TIMED INTENSIVE MODE (Reduces automatically after 5 minutes\*)
- 3 Motor ON - SPEED 3 Maximum Speed for Normal Use
- 2 Motor ON - SPEED 2
- 01 Motor ON - SPEED 1 Motor OFF
- ☀ Lights ON/OFF

**The extractor controller automatically switches off the appliance if there has been no operator action for 4 hours.**

After 30 hours accumulated running GREASE FILTER CLEANING will be signalled by all 6 indicators flashing. Reset by pressing (⏻).

\*\*Speed 4 reduces automatically to Speed 3 after 5 minutes

**Light Dimming**

To adjust the light intensity, press & hold (☀) until desired intensity is set.

**Colour Changing**

Ensure that the fan, lights & timer are off. Press and hold (⏻) until the lights illuminate. Then press and hold (☀) until the desired light colour is achieved. Press SPEED 1 button to confirm the desired light preference. (or + if using the remote control).

**The appliance will automatically switch off if there has been no operator action for 4 hours.**

#### Radio Remote Controlled Models

- Switch on the power at the fused spur.
- Then Immediately turn on the remote control (⏻).
- Then immediately press and hold (☀) until the lights illuminate.

Should the extractor fail to respond to commands from the remote-control, please check that the power is 'on' and the internal appliance reset switch is in the 'ON' position (factory default). The reset switch is a latching red push-switch located in the chamber behind the door panel / filter.

If you experience interference problems, or the remote appears to be faulty from new, then a different radio transmission code may be required. Refer to the instruction leaflet included with the remote control regarding transmission code changes before seeking assistance.

#### Remote Control Functions

- ☀ Light Function (If Option Fitted)
- ⏻ Run-On Timer (Motor OFF After 10 Minutes) (To cancel, select different fan speed)
- ☀ LCD Display
- + Increase Speed\*\*
- Decrease Speed\*\*
- ⏻ Motor Power ON/OFF

*\* The automatic speed reduction feature is required by EU Ecodesign and Energy Labelling Commission Legislation 65/2015 66/2014 in order to satisfy Directive 2009/125 EC*

Refer to the instruction leaflet included with the radio remote control regarding pairing the device, transmission codes and factory reset procedures.

#### Other Control Systems

Because this is a custom-made product, an alternative control system may have been specified during the design phase.

Most commonly this alternative control system will be a continuously variable rotary fan speed controller plus light control mounted on the extractor (usually the baseplate). With most such control systems, you will find on/off switches for the fan and lights and a rotating knob to adjust the fan speed. Sometimes the switch and knob are combined into a single unit, like a domestic lighting dimmer switch, which is pressed for on/off function and turned for speed.

In some cases, the fan control may have been specified as a separate item that does not form part of the extractor (e.g. a wall mounted controller). Such controllers may have been supplied by Westin or a third party and are not covered by this manual.

If you are unsure how to operate your unit then please call Westin for assistance



## Prime EDGE 800 - 1100 Built-in Extractor Installation, Operating & Maintenance Instructions

### 9. MAINTENANCE

Regular maintenance is essential to ensure good performance and long-life.

#### CAUTION

To minimise the risk of fire, all instructions relating to cleaning the grease filters and removing grease deposits must be adhered to.

To minimise fire risk, ensure that grease deposits on the extractor surfaces are kept to a minimum by regular cleaning.

To clean the stainless-steel surfaces of the extractor, use a soft cloth and a suitable cleaning agent, such as a specially produced stainless-steel cleaner or washing up detergent and warm water.

Painted surfaces should be cleaned using a soft cloth, detergent and warm water.

Glass surfaces should be cleaned with a suitable glass cleaning agent.

**Do not use abrasive cleaning materials or products.**

**Do not use bleach-based cleaning materials or products.**

Clean the grease filters in a dishwasher or by hand-washing in hot water and detergent every 2 months - sooner if the extractor is used extensively and filters become grease laden.

Whilst you can expect years of service from mesh grease filters, they are considered a consumable item and may deteriorate over time and need replacement, particularly when cleaned in a dishwasher. For dishwasher users adhering to a 2 monthly cleaning interval, we recommend grease filter replacement every 5 years to maintain optimum performance, even if they show no visible signs of deterioration. For all users, filters should be replaced whenever they exhibit signs of physical wear.

#### Removing the Grease Filters

The clip in grease filters have an integrated sprung latch mechanism.

Release the latch by pulling the lever and remove the filter.

Filters are replaced by locating the fixed tabs opposite the lever catch into corresponding slots in the extractor base and then pushing the filter into position with the latch held open. Once the filter is in position, release the lever, allowing the latch to engage.

#### Replacing LED lighting

The long-life LED units are not designed for end user replacement. In the unlikely event of failure please call Westin to arrange a Service call.

## Prime EDGE 800 - 1100 Built-in Extractor Installation, Operating & Maintenance Instructions

### STANDARD GUARANTEE CONDITIONS

Westin Ltd undertakes that if within 24 months of the date of delivery this product or any part thereof is proved to be defective by reason only of the faulty workmanship or materials, the company will, at our option, repair or replace the same FREE OF ANY CHARGE for labour, materials or carriage on condition that:

1. The product has been correctly installed and used only on the electrical supply stated on the rating plate.
2. The product has been used for normal domestic purpose only, and in accordance with the manufacturer's operating and maintenance instructions.
3. The product has not been serviced, maintained, repaired, taken apart or tampered with by any person not authorised by us.

### EXCLUSIONS

#### **This Guarantee does not cover:**

- Damage or calls resulting from incorrect installation, transportation, improper use or neglect, the replacement of any light bulbs or removable parts of glass or plastic.
- Costs incurred for calls to put right appliances improperly installed or calls to appliances outside the United Kingdom.
- Normal wear and tear.
- Products deemed to be in use within a commercial environment.
- Grease filter mesh.
- Bulbs and LEDs.
- Consumables.
- Damage caused to the body by usage of detergent sprayer or other contaminants.
- Damage or corrosion of the LED parts, glass parts and stainless-steel parts.
- Damage caused by foreign objects or accident.
- Any products taken apart or serviced by unauthorised individuals or service engineers or replaced with other manufacturer's components.
- Product not installed with the correct size ducting as stated in the manual.

This Guarantee is in addition to your statutory and legal rights.

Please see our website [www.westin.co.uk](http://www.westin.co.uk) for details of our Conditions of Sale and to register your guarantee.