



# WESTIN

## TRADITIONAL

### Wall Mounted Extractor

#### Installation, Operation and Maintenance

INTRODUCTION	2
IMPORTANT INFORMATION	2
EXTRACTION PERFORMANCE	2
INSTALLATION	3
ILLUSTRATIONS	5
REMOTE MOTOR WIRING	9
OPERATING INSTRUCTIONS	10
MAINTENANCE	11
SPECIFICATIONS	11
GUARANTEE	12

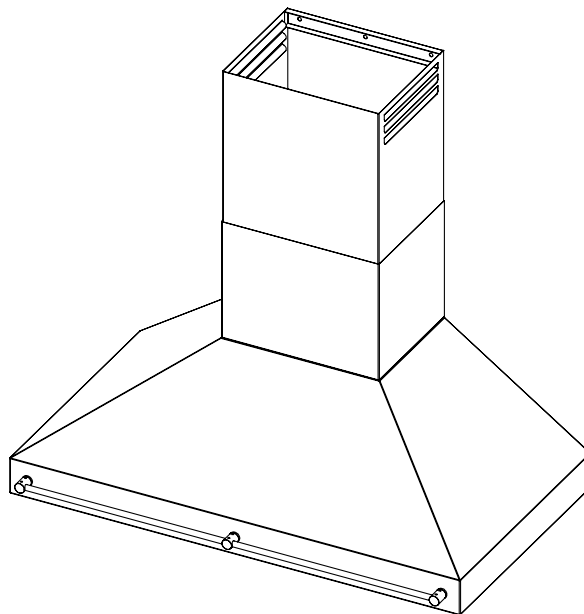

#### **UNPACKING**

Remove all items from the packaging. Retain the packaging.  
If items are missing or damaged, please contact Westin for assistance.



# Traditional Wall Mounted Extractor Installation, Operating & Maintenance Instructions

## 1. INTRODUCTION

During the cooking process, there will be heat, vapours and fumes produced. Your Extractor has been designed to complement your kitchen both in looks and performance in order to create a good environment for creative cooking.

## 2. IMPORTANT INFORMATION

The exhaust air **must not** be discharged into a flue which is used for exhausting fumes from non-electric appliances such as oil or gas-fired central heating boilers or gas-fired water heaters, etc.

Requirements of the relevant authorities concerning the discharge of exhaust air must be complied with.

Pay particular attention to fire risk when frying. To minimise the risk of fire, all instructions relating to cleaning the grease filters and removing grease deposits must be adhered to.

Do not flambé under the extractor.

### WARNING

Proper care must be taken to ensure that the negative pressures caused by high performance extraction systems do not adversely affect the safe operation of certain types of fuel-burning appliances (gas, oil or solid fuel), including those installed in the kitchen and possibly those installed in other parts of the house.

Where such fuel-burning appliances are installed, adequate ventilation **MUST** be provided in the room of installation, located and sized such that the negative pressure in the room created by the extractor does not exceed 4Pa.

In case of doubt, do not operate the extractor and fuel-burning appliance(s) simultaneously and consult an appropriate (for the fuel type) expert for advice.

**The clearance between the hob burners and the bottom surface of the cooker hood (extractor) should be within the following range, unless a greater distance is specified by the cooking appliance manufacturer:**

### Hob to underside of the cooker hood clearance distances:

- 650mm minimum above electric hobs.
- 760mm minimum above all gas hobs and gas or electric wok burners, griddles, fryers, open grills / barbecues.
- 850mm is the maximum recommended distance between the hob and underside of the cooker hood.

The minimum distance between the hob and the bottom of the cooker hood is essential for safety reasons and to prevent overheating of the extractor and its components.

Exceeding the maximum clearance distance will reduce how efficiently the cooker hood removes cooking fumes and odours.

**You are advised to install measures designed to reduce the incidence of cold draughts entering the property via any ductwork.**

For extractors with internal or inline fans, this should (at the very least) consist of an external duct termination with integrated non-return flaps (e.g. gravity shutter wall grille/louvre) and/or an inline backdraught shutter.

For wall-mounted fans an inline backdraught shutter is recommended.

## 3. EXTRACTION PERFORMANCE

The primary influence on the overall performance of the extractor is the design of the ducting which takes the exhaust air from the extractor to the outside. The duct route should be a prime consideration during the initial stages of the kitchen design (The manufacturer does not recommend recirculating air back into the kitchen).

### Please note the following:

- Easy access to the duct route during installation is important. Lack of access may require the "blind" fitting of flexible ducting, with increased risk of unseen kinks and impaired efficiency.
- **The extractor is provided with a spigot(s) suitable for connecting 150mm round ducting (or equivalent cross section). Ducting must not be reduced.**

**Note: Failure to adequately fit the ducting stated above will void your written Guarantee under the Standard Guarantee conditions.**

Because this is a bespoke product, alternative arrangements may have been agreed during the design phase for connection of your ducting.

- The most efficient configuration is to duct straight through an outside wall so try to position the cooker against an outside wall when designing your kitchen.
- If your extractor has adjustable exhaust positions then use the exhaust position which gives the shortest achievable duct route and least number of bends.
- Well installed, correctly sized rigid round ducting or an equivalent flat channel system will usually perform best, with round semi-rigid ducting being an alternative. Flexible ducting is economical but its use should be minimised as it gives the worst performance and should only be used for short duct runs or initial connection and should be pulled taut to prevent significant losses in extraction efficiency.
- For maximum efficiency, ducting should be kept as short and as straight as possible with a constant cross-sectional area being no less than that recommended by the manufacturer. Bends in the duct will degrade performance so the number of bends in a duct run should be kept to a minimum and be gradual and smooth to prevent turbulence. Avoid kinks in flexible ducting. Pulling the ducting taut over straight runs will ensure that the internal surface is as smooth as possible.
- If using rigid ducting you may wish to consider making the initial duct connection to the extractor using semi-rigid (or flexible, if unavoidable) round ducting to facilitate easier installation and future maintenance.  
  
If the duct spigot is accessible with the unit installed and it will remain so in the completed kitchen (e.g. behind a removable chimney) then no flexible connection need be used.
- Ducting and associated components, including complete kits are generally available.

### ELECTRICAL SAFETY

This appliance requires an earth connection.

Ensure that the supply voltage corresponds to that marked on the rating label inside the extractor.

The extractor must be isolated from the electrical supply before carrying out any cleaning or maintenance operations.



# Traditional Wall Mounted Extractor Installation, Operating & Maintenance Instructions

## 4. INSTALLATION

This document provides detailed guidance for a typical installation, however not all installations can be accommodated within this guide.

If you are unsure how to proceed then please call Westin for assistance.

To install the hood, it is necessary to remove the filters to gain access to the wall fixing holes, and electrical supply cords & connections.

### General Installation

Remove the filters by opening the mechanical catch located at one end of the filter.

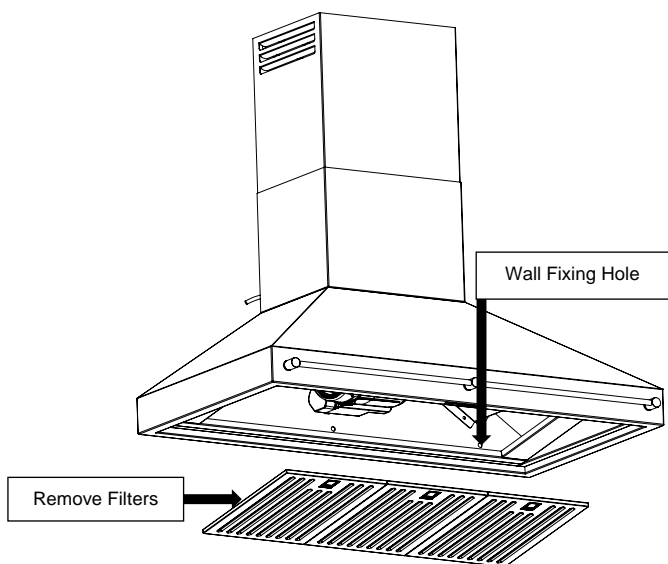

Once the filters have been removed, locate the wall fixing holes located at the rear bulk head of the appliance.

### Duct Spigot Position

The appliance will be supplied with either a top outlet exhaust or a rear outlet exhaust.

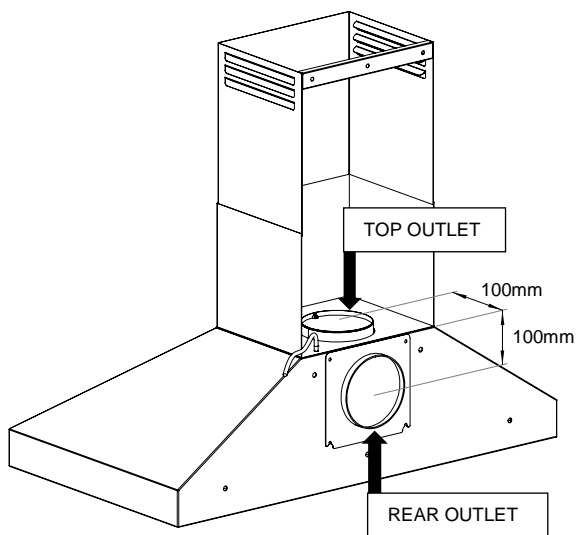

### Moving the fan for a rear outlet position

In order to re-position the fan for a rear outlet position from the extractor: Expose the fan by removing the filters. Locate and remove the 4 fan retaining nuts and washers. Lower the fan. Remove the fixings retaining the blanking plate in the rear of the extractor and re-position the blanking plate in the top outlet position. Rotate the fan into the rear outlet orientation and fit to the rear of the extractor (where the blanking plate once was) and re-fit the washers and nuts. If fitted, ensure that the thin steel brackets remain connected to the fan and fan bracket.

If the top outlet exhaust option has been selected, but the ducting routes through a wall to the rear, then the installation will require 215mm minimum head room in order to achieve a smooth 90° bend using 150mm flexible ducting.

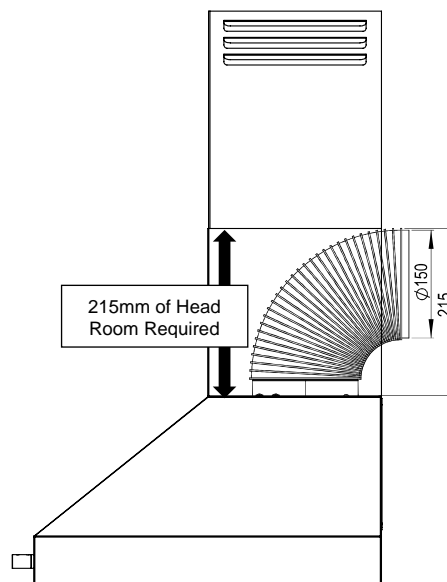

### Duct Installation

Install ducting taking note of the advice given in SECTIONS 2 and 3. It is recommended to use a length of semi-rigid ducting for the final connection to the extractor spigot as this will allow the unit to be pushed into final position with the duct connected. If your extractor has multiple spigots, you will usually require separate duct runs to the outside or to the remote fan(s).

If terminating on an outside wall, a suitable weather louvre should be fitted. Various ducting components and complete kits are generally available to suit most installations.

If using expanding foam, make sure any flexible ducting is supported internally to prevent crushing.

For roof or chimney duct terminations, please seek specialist advice.

### Remote motors

Hoods intended for use with alternative remote fans will have suitable provisions for their electrical connection (usually Live, Neutral and Earth terminals, switched by the extractor) – these provisions will usually be labelled to avoid confusion.

Note: Not all coloured terminals will be used because each remote motor type is configured differently.

Some types of external fan may require a separate power supply.

The fan should be installed in accordance with any installation instructions that accompany it.

Fan extension kits for standard fans are generally available. Alternatively, providing you use an electrician to carry out the work,



# Traditional Wall Mounted Extractor Installation, Operating & Maintenance Instructions

the cable can be extended using suitable flex. Ensure that where the cable has been cut the numbered or coloured wires are re-connected correctly

Detailed wiring illustrations and wiring instructions for remote motors can be found on page 6.

## Fixing the Extractor to the Wall

Fixing the extractor safely into position requires two people, so do not start if assistance is unavailable.

Locate the fixing holes in the rear panel (as previously described). Offer the hood up to the wall in the desired position and mark the wall through the fixing holes. Ensure that the appliance is level. Please be sure to check that any chimney previously removed can be re-attached when the hood is secured in this position (adjust position as necessary).

Secure the hood using suitable fixings (not supplied) in the previously marked positions.

The supporting wall must be of good quality, have an even surface and be sturdy enough to support the extractor.

Fixings must be used which are suitable for the type of wall construction.

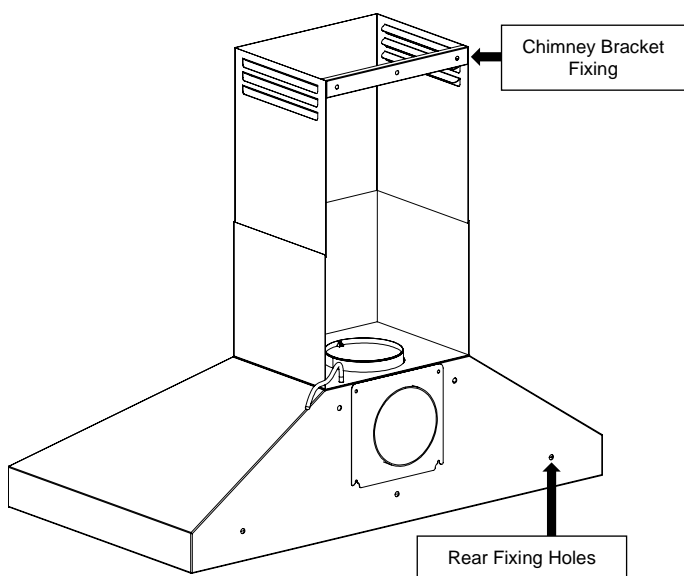

## Connecting the Ducting

Terminate the ducting where it exits the building. If using a wall mount weather louvre, secure the ducting to the louvre spigot and attach the louvre to the wall. Ensure that the air fins are directed downwards. If you are fitting an alternative termination without a spigot, ensure that the ducting is secure.

If using expanding foam, make sure that flexible ducting is supported internally to prevent it crushing or use rigid ducting through the wall where foamed.

Install remaining ductwork ensuring any flexible ducting is taut and smooth. Secure ducting to the extractor exhaust spigot(s) using straps (e.g. jubilee clip). Do not use duct tape as the only fixing.

Check that the duct has not been flattened or kinked

## Electrical Installation

**ELECTRICAL HAZARD.  
DISCONNECT ELECTRICAL SUPPLY BEFORE  
PROCEEDING FURTHER**

The extractor is a stationary appliance supplied with an electrical supply flex and moulded 3 pin UK plug (3A) for connection to the electrical supply.

The appliance must be fed from a 230Vac single phase electrical supply. You may wish to terminate the electrical supply using a standard mains electrical socket positioned close to the extractors intended location.

Alternatively, you may terminate the electrical supply from a switched-fused spur. The spur should be located adjacent to the hood/cooker so that the supply can be disconnected from the hood using the switch. The means of disconnection from the supply must have a minimum contact separation of 3mm in all poles. A competent Part P registered electrical technician must perform the electrical installation.

The mains supply is connected as follows:

INCOMING SUPPLY CORD CONNECTIONS	
Core	Core Colour
Live	Brown
Neutral	Blue
Protective Earth	Green/Yellow

Make electrical connections for any remote motors, as described earlier.

As a bespoke hood, it may be that other electrical connections were agreed for your hood, such as connections to control the lighting from elsewhere or to operate other electrical devices. Make any remaining electrical connections now.

## Finalise Installation

Finish the installation by re-fitting any parts previously removed and attach any chimney / cladding panels or parts supplied separately.

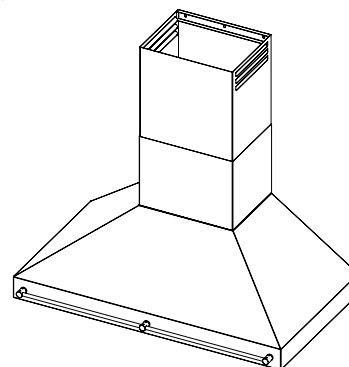

## Main Reset Switch

The Reset Switch is a red rectangular switch located inside the extractor. The Switch can be accessed by removing the Filter(s). Press the Reset Switch to unlatch 'out'. Press the Reset Switch again to relatch 'in'. The Switch must be in the latched 'in' position in order for the extractor to operate.

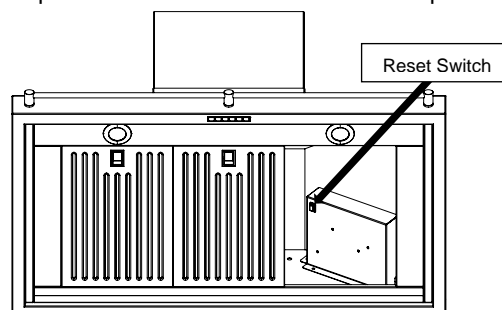



# Traditional Wall Mounted Extractor Installation, Operating & Maintenance Instructions

## TRADITIONAL LAYOUT INTERNAL MOTOR VARIANT

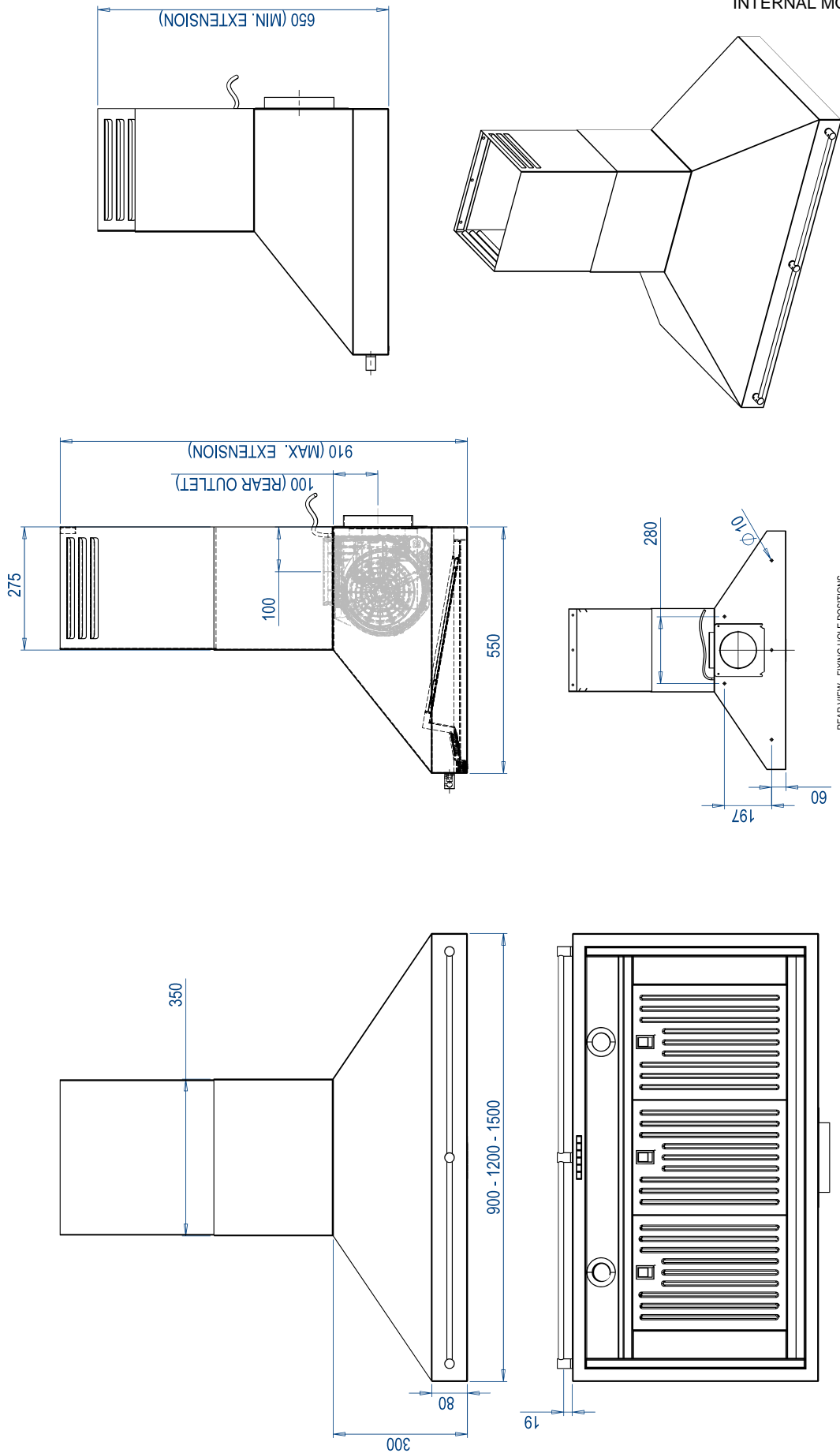



# Traditional Wall Mounted Extractor Installation, Operating & Maintenance Instructions

## TRADITIONAL LAYOUT EXTERNAL MOTOR VARIANT

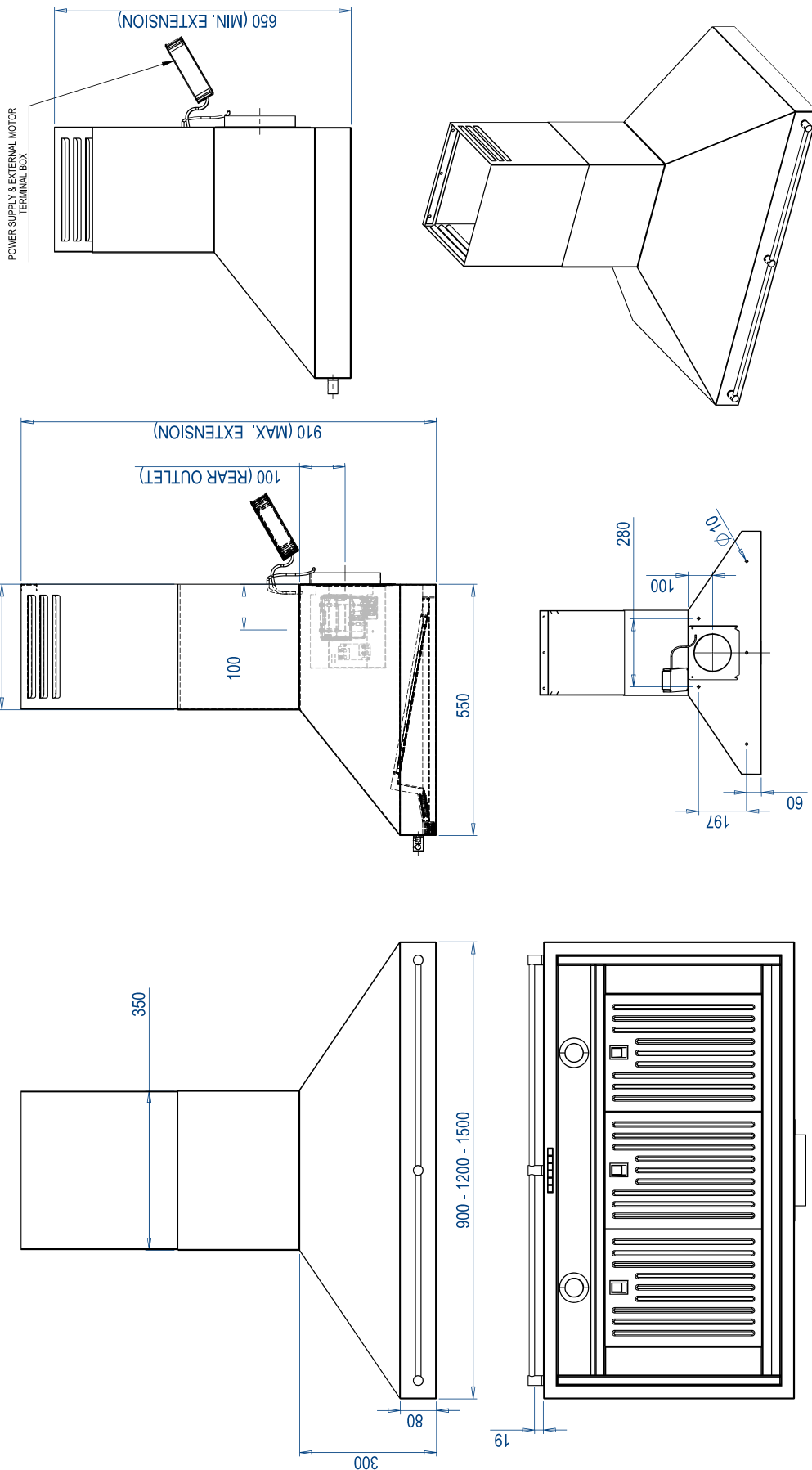

# Traditional Wall Mounted Extractor Installation, Operating & Maintenance Instructions



## TRADITIONAL LAYOUT INTERNAL MOTOR VARIANT EXPLODED PARTS LIST

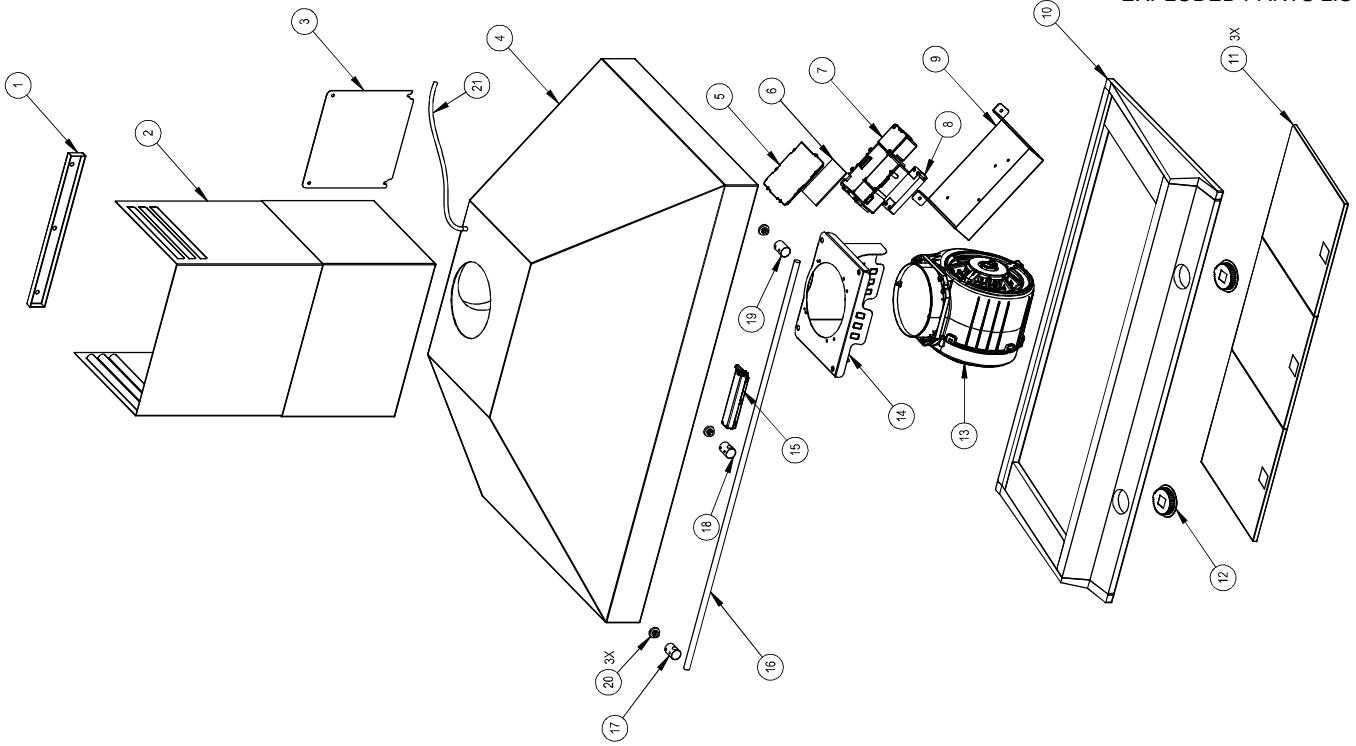

NO.	Part Name	Part Number	Notes & Special Ordering Instructions
1	Chimney Bracket	Made to Order	
2	Chimney	Made to Order	
3	Blanking PLate	Made to Order	
4	Extractor Body	Made to Order	
5	Circuit Board Housing Lid	*W0490	
6	Circuit Board	*W2037	
7	Circuit Board Housing	*W0419 - *W0421 - *W0422	
8	Lighting Driver	W1094	
9	Control Box Enclosure	Made to Order	
10	Extractor Base Plate	Made to Order	State Hood Width
11	Grease Filter	W1371	
12	LED Lights	W1729	Refer to Table for Quantity
13	Motor	*W1437	
14	Motor Bracket	Made to Order	
15	Pushbutton Module	W1742	
16	Pan Rail	W1847	Chrome Option
	Pan Rail	W1848	Machined Steel Option
17	Pan Rail Post (LHS)	W1842	Chrome Option
	Pan Rail Post (LHS)	W1838	Machined Steel Option
18	Pan Rail Post (Centre)	W1844	Chrome Option
	Pan Rail Post (Centre)	W1840	Machined Steel Option
19	Pan Rail Post (RHS)	W1844	Chrome Option
	Pan Rail Post (RHS)	W1840	Machined Steel Option
20	Pan Rail Boss	W1843	Chrome Option (x3 Required)
	Pan Rail Boss	W1839	Machined Steel Option (x3 Required)
21	Schuko Power Cable	W1490	
	Internal Motor Assembly	W1788	*Parts Included With Assembly

# Traditional Wall Mounted Extractor Installation, Operating & Maintenance Instructions



## TRADITIONAL LAYOUT EXTERNAL MOTOR VARIANT EXPLODED PARTS LIST

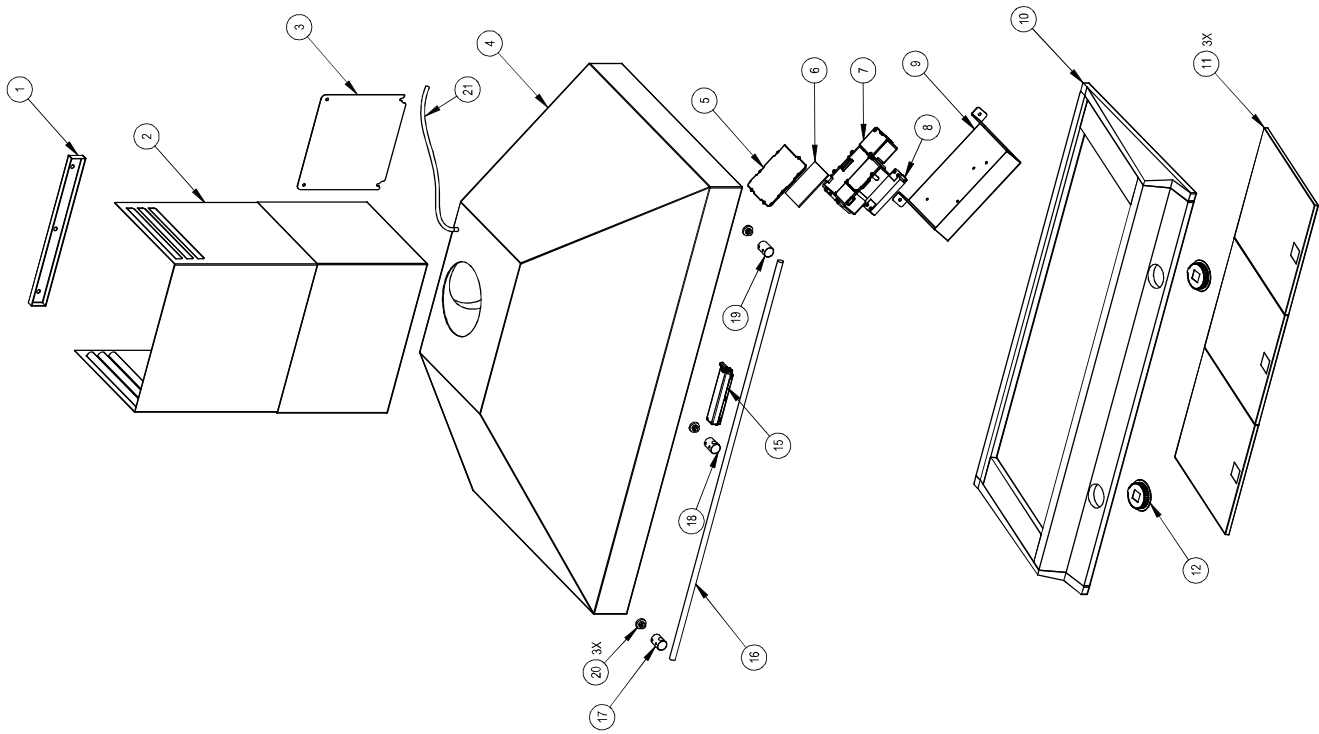

NO.	Part Name	Part Number	Notes & Special Ordering Instructions
1	Chimney Bracket	Made to Order	
2	Chimney	Made to Order	
3	Blanking Plate	Made to Order	
4	Extractor Body	Made to Order	
5	Circuit Board Housing Lid	*W0490	
6	Circuit Board	*W2037	
7	Circuit Board Housing	*W0419 - *W0421 - *W0422	
8	Lighting Driver	W1094	
9	Control Box Enclosure	Made to Order	
10	Extractor Base Plate	Made to Order	State Hood Width
11	Grease Filter	W1371	
12	LED Lights	W1729	Refer to Table for Quantity
15	Pushbutton Module	W1742	
16	Pan Rail	W1847	Chrome Option
17	Pan Rail	W1848	Machined Steel Option
18	Pan Rail Post (LHS)	W1842	Chrome Option
18	Pan Rail Post (LHS)	W1838	Machined Steel Option
18	Pan Rail Post (Centre)	W1844	Chrome Option
19	Pan Rail Post (Centre)	W1840	Machined Steel Option
19	Pan Rail Post (RHS)	W1844	Chrome Option
19	Pan Rail Post (RHS)	W1840	Machined Steel Option
20	Pan Rail Boss	W1843	Chrome Option (x3 Required)
20	Pan Rail Boss	W1839	Machined Steel Option (x3 Required)
21	Schuko Power Cable	W1490	
	External Motor Assembly	W2017	*Parts Included With Assembly



# Traditional Wall Mounted Extractor Installation, Operating & Maintenance Instructions

## 5. SEM EL REMOTE MOTOR WIRING

The wiring illustrations below apply to SEM EL Motors only.

The below diagram shows a typical SEM EL wiring schematic. The appliance is supplied with an external terminal box that requires connecting to the external motor.

In order to access the electrical terminals, remove the fixing screws from the external terminal box lid. Refer to fig. 2 & 3 for details of how to wire the SEM 1/2 or SEM 7/8 correctly.

Fig. 1 Typical System

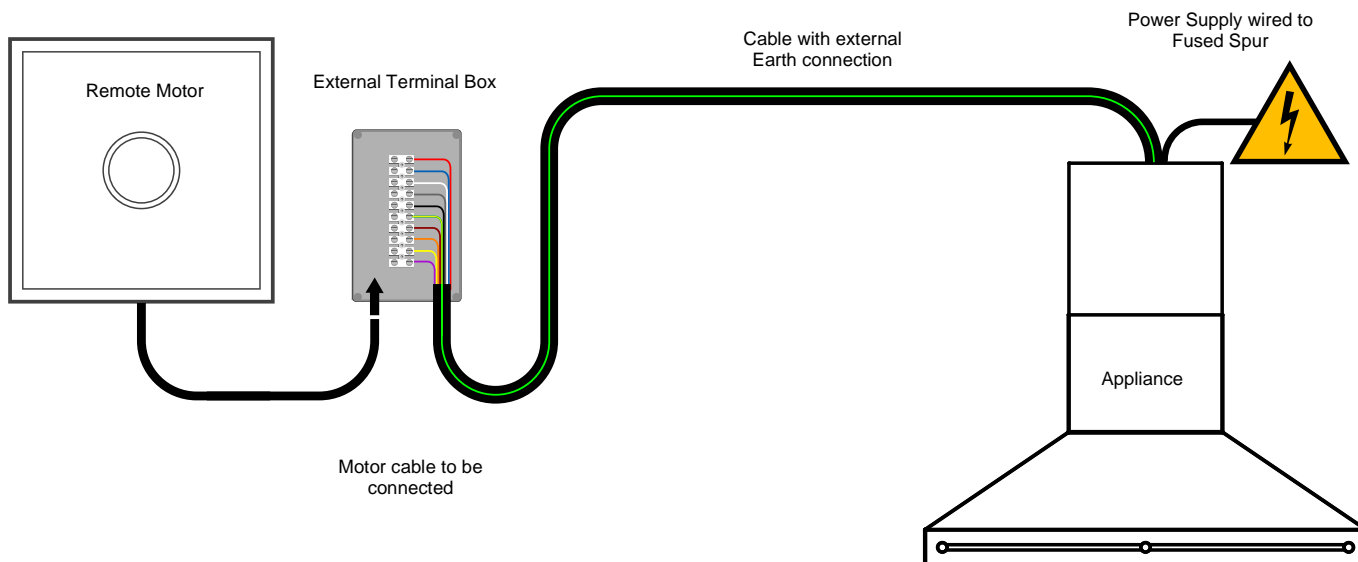

Fig. 2 Terminal Colour Positions

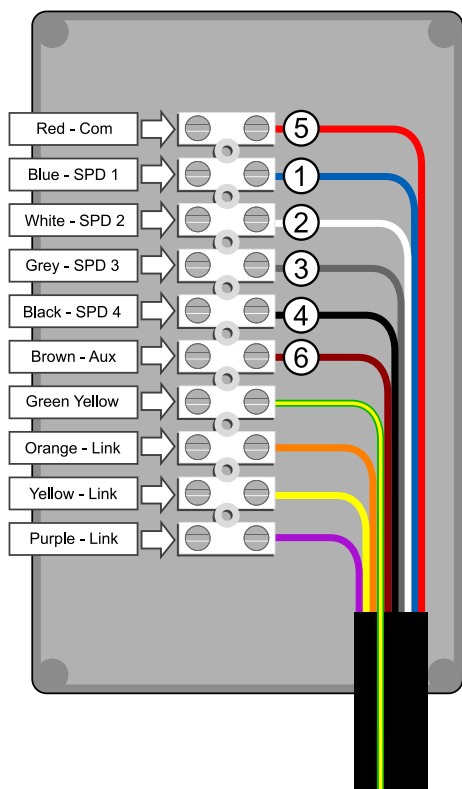

Fig. 3 SEM 1 / SEM 2  
Electrical Connections

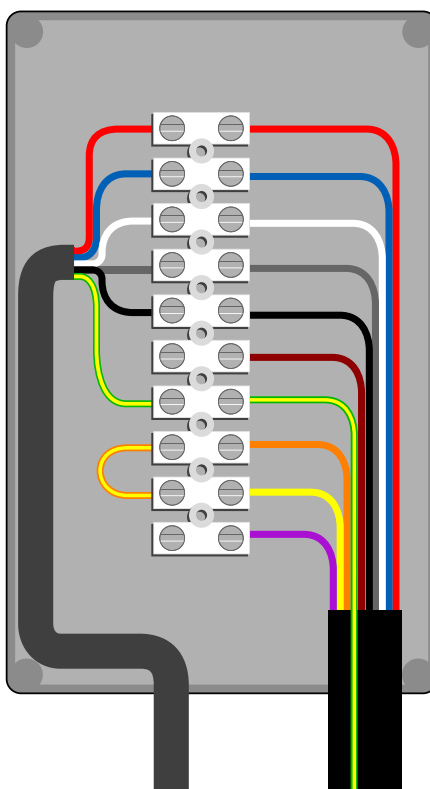
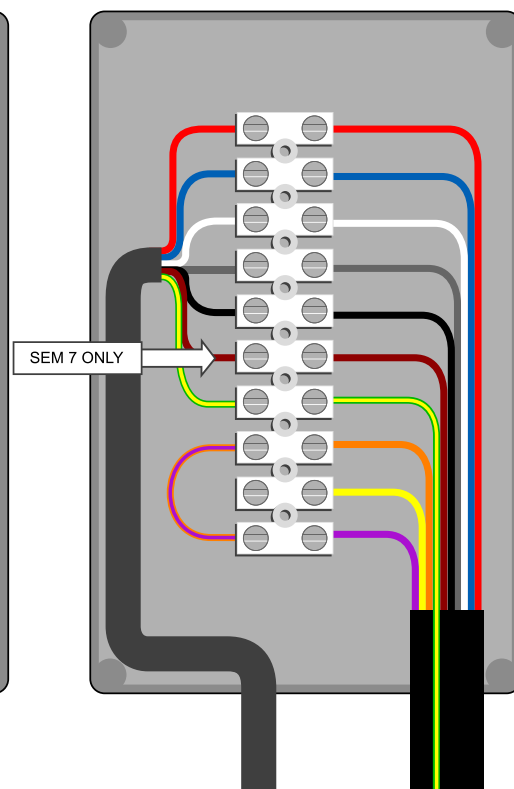

Fig. 4 SEM 7 / SEM 8  
Electrical Connections



**Note:**  
**CHECK: COLOUR SEQUENCE MAY VARY**  
Link terminals determine intensive speed run times, which are motor type dependent.  
Aux terminal powers auxiliary PCB in some motors.

Remote Motor Cable Assembly  
Orange/Yellow link wire is included

Remote Motor Cable Assembly  
(Orange/Purple link wire is included)



# Traditional Wall Mounted Extractor Installation, Operating & Maintenance Instructions

## 6. OPERATING INSTRUCTIONS

### Radio Remote Controlled Models

- Switch on the power at the fused spur.
- Then Immediately turn on the remote control (⏻).
- Then immediately press and hold (☼) until the lights illuminate.

Should the extractor fail to respond to commands from the remote-control, please check that the power is 'on' and the internal appliance reset switch is in the 'ON' position (factory default). The reset switch is a latching red push-switch located in the chamber behind the door panel / filter.

If you experience interference problems, or the remote appears to be faulty from new, then a different radio transmission code may be required.

Refer to the instruction leaflet included with the remote control regarding transmission code changes before seeking assistance.

### Pushbutton Models

### Pushbutton Functions

(For models with pushbutton controls)

	01	2	3	4	
Lights ON/OFF	Motor ON - SPEED 1 Motor OFF	Motor ON - SPEED 2	Motor ON - SPEED 3 Maximum Speed for Normal Use	Motor ON - TIMED INTENSIVE MODE (Reduces automatically after 5 minutes*)	Motor RUN ON TIMER (OFF after 10 minutes)

**The extractor controller automatically switches off the appliance if there has been no operator action for 4 hours.**

After 30 hours accumulated running GREASE FILTER CLEANING will be signalled by all 6 indicators flashing. Reset by pressing (⊖).

**Light Dimming**  
To adjust the light intensity, press & hold (☼) until desired intensity is set.

**Colour Changing**  
Ensure that the fan, lights & timer are off. Press and hold (⊖) until the lights illuminate. Then press and hold (☼) until the desired light colour is achieved. Press SPEED 1 button to confirm the desired light preference. (or + if using the remote control).

### Remote Control Functions

\* The automatic speed reduction feature is required by EU Ecodesign and Energy Labelling Commission Legislation 65/2015 66/2014 in order to satisfy Directive 2009/125 EC

**The extractor controller will automatically switch off the appliance if there has been no operator action for 4 hours.**

Refer to the instruction leaflet included with the radio remote control console regarding pairing the device, transmission codes and factory reset procedures.

### Other Control Systems

Because this is a custom-made product, an alternative control system may have been specified during the design phase.

Most commonly this alternative control system will be a continuously variable rotary fan speed controller plus light control mounted on the extractor (usually the baseplate). With most such control systems, you will find on/off switches for the fan and lights and a rotating knob to adjust the fan speed. Sometimes the switch and knob are combined into a single unit, like a domestic lighting dimmer switch, which is pressed for on/off function and turned for speed.

In some cases, the fan control may have been specified as a separate item that does not form part of the extractor (e.g. a wall mounted controller). Such controllers may have been supplied by the manufacturer or a third party and are not covered by this manual.

If you are unsure how to operate your unit then please call the manufacturer for assistance.



# Traditional Wall Mounted Extractor Installation, Operating & Maintenance Instructions

## 7. MAINTENANCE

Regular maintenance is essential to ensure good performance and long-life.

### CAUTION.

To minimise the risk of fire, all instructions relating to cleaning the grease filters and removing grease deposits must be adhered to.

To maintain the immaculate appearance of the extractor, and to minimise fire risk, ensure that grease deposits on the extractor surfaces are kept to a minimum by regular cleaning.

To clean the stainless-steel surfaces of the extractor, use a soft cloth and a suitable cleaning agent, such as a specially produced stainless-steel cleaner or washing up detergent and warm water.

Painted surfaces should be cleaned using a soft cloth, detergent and warm water.

Glass surfaces should be cleaned with a suitable glass cleaning agent.

**Do not use abrasive cleaning materials or products.**

**Do not use bleach-based cleaning materials or products.**

Clean the grease filters in a dishwasher or by hand-washing in hot water and detergent every 2 months - sooner if the extractor is used extensively and filters become grease laden.

If your hood has mesh grease filters, you can expect years of service from them however, they are considered a consumable item and may deteriorate over time and need replacement, particularly when cleaned in a dishwasher. For dishwasher users adhering to a 2 monthly cleaning interval, we recommend grease filter replacement every 5 years to maintain optimum performance, even if they show no visible signs of deterioration. For all users, filters should be replaced whenever they exhibit signs of physical wear.

### Removing the Grease Filters

Release the grease filter integrated sprung latch by pulling the lever. Remove the filter. The filter is replaced by locating the fixed tabs opposite the lever catch into corresponding slots in the baseplate and then pushing the filter into position with the latch held open. Once the filter is in position carefully release the lever, allowing the latch to engage.

For units supplied with concealed filters, the filters are located behind a hinged panel. This panel is held shut with magnetic catches. Open the panel by grasping it in corners opposite the hinged side.

### LED lamp replacement

The long-life LED units are not designed for end user replacement. In the unlikely event of failure please call the manufacturer to arrange a Service Call.

### Caring for HP4 high efficiency carbon filters (Recirculating hoods only).

To restore and regenerate high efficiency HP4 carbon filters, they must be washed in the dishwasher (without other dishes or cookware) and then be placed into an oven for 1 hour at max 90°C.

HP4 filters should be washed whenever they are dirty or lose effectiveness (at least every two months).

Regular washing and regeneration will maximise the efficiency and lifespan of these filters.

These filters can be regenerated repeatedly but are considered a consumable and will eventually deteriorate, after which they should be replaced. The time this takes will depend on the style of cooking but they can be expected to deliver excellent service under normal use conditions, although replacement is recommended at least every two years.

## 8. SPECIFICATIONS

A 3A fuse for the electrical supply is usually sufficient. Units with multiple fans fitted may require a 5A fuse.

**In all cases, because this is a custom made product you must refer to the rating plate inside the extractor and any remote motor and consult with your electrician to determine the correct electrical supply fuse required to protect you, your property and the appliance.**

**If your unit has been supplied to work with a remote or third party fan then you should consult the rating plate of both the extractor and fan(s) in order to determine the electrical load of the system and size your fuse accordingly.**

Electrical System - All Models	
Supply voltage:	230V~ 50Hz
LED voltage	12V
Total power:	See rating plate
Units with Internal GPE800 Fan	
Fan airflow in free air:	800m <sup>3</sup> /hr
Fan power input:	275W
Spigot Diameter	150mm

**Do not install ducting smaller in diameter than the extractor duct spigot diameter as to do so will reduce performance and may damage the product.**

# Traditional Wall Mounted Extractor Installation, Operating & Maintenance Instructions



## STANDARD GUARANTEE CONDITIONS

Westin Ltd undertakes that if within 24 months of the date of delivery this product or any part thereof is proved to be defective by reason only of the faulty workmanship or materials, the company will, at our option, repair or replace the same FREE OF ANY CHARGE for labour, materials or carriage on condition that:

1. The product has been correctly installed and used only on the electrical supply stated on the rating plate.
2. The product has been used for normal domestic purpose only, and in accordance with the manufacturer's operating and maintenance instructions.
3. The product has not been serviced, maintained, repaired, taken apart or tampered with by any person not authorised by us.

## EXCLUSIONS

### This Guarantee does not cover:

- Damage or calls resulting from incorrect installation, transportation, improper use or neglect, the replacement of any light bulbs or removable parts of glass or plastic.
- Costs incurred for calls to put right appliances improperly installed or calls to appliances outside the United Kingdom.
- Normal wear and tear.
- Products deemed to be in use within a commercial environment.
- Grease filter mesh.
- Bulbs and LEDs.
- Consumables.
- Damage caused to the body by usage of detergent sprayer or other contaminants.
- Damage or corrosion of the LED parts, glass parts and stainless-steel parts.
- Damage caused by foreign objects or accident.
- Any products taken apart or serviced by unauthorised individuals or service engineers or replaced with other manufacturer's components.
- Product not installed with the correct size ducting as stated in the manual.

This Guarantee is in addition to your statutory and legal rights.

Please see our website [www.westin.co.uk](http://www.westin.co.uk) for details of our Conditions of Sale and to register your guarantee.