



WESTIN

BLOQUE PRO

Built-in Unit

Installation, Operation and Maintenance

INTRODUCTION	1
IMPORTANT INFORMATION	1
EXTRACTION PERFORMANCE	1
INSTALLATION	2
SPECIFICATIONS	4
MAINTENANCE	4
OPERATING INSTRUCTIONS	5
DRAWINGS & ILLUSTRATIONS	6
GUARANTEE	10

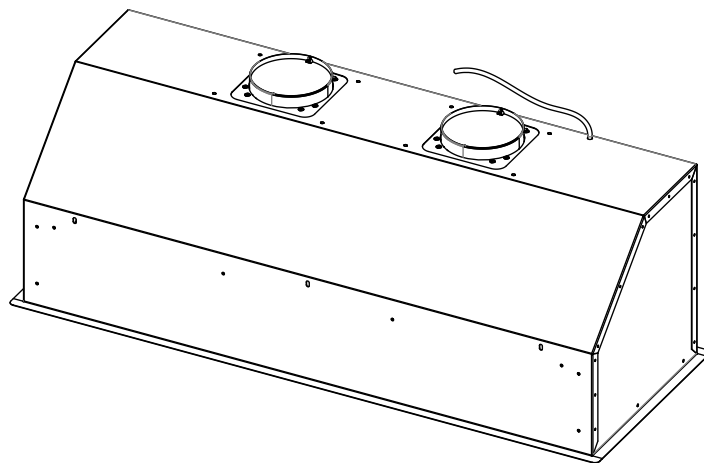

Unpacking

Remove all items from the packaging. Retain the packaging. If items are missing or damaged, please contact Westin for assistance.



Installation, Operating & Maintenance Instructions

1. INTRODUCTION

During the cooking process, there will be heat, vapours and fumes produced. Your Westin *Bloque Pro* built-in extractor has been designed to complement your kitchen both in looks and performance in order to create a good environment for creative cooking and is ideal for applications where a conventional cooker hood is neither suitable nor desirable (in an inglenook chimney or kitchen furniture above the hob for example).

2. IMPORTANT INFORMATION

The exhaust air must not be discharged into a flue which is used for exhausting fumes from appliances supplied with energy other than electricity e.g. oil or gas-fired central heating boilers, gas-fired water heaters, etc.

Requirements of the relevant authorities concerning the discharge of exhaust air must be complied with.

WARNING

Proper care must be taken to ensure that the negative pressures caused by high performance extraction systems do not adversely affect the safe operation of certain types of fuel-burning appliances (gas, oil or solid fuel), including those installed in the kitchen and also those installed in other parts of the house.

Where such fuel-burning appliances are installed, adequate ventilation **MUST** be provided in the room of installation, located and sized such that the negative pressure in the room created by the extractor does not exceed 4Pa.

In case of doubt, do not operate the extractor and fuel-burning appliance(s) simultaneously and consult an appropriate (for the fuel type) expert for advice.

ELECTRICAL SAFETY

This appliance requires an earth connection.

Ensure that the supply voltage corresponds to that marked on the rating label inside the extractor.

The extractor must be isolated from the electrical supply before carrying out any cleaning or maintenance operations.

Pay particular attention to fire risk when frying. To minimise the risk of fire, all instructions relating to cleaning the grease filters and removing grease deposits must be adhered to.

Do not flambé under the extractor.

The clearance between the hob and the lowest part (base) of the extractor should be within the following range, unless a greater distance is specified by your cooking appliance or furniture manufacturer:

- **minimum clearance distances:**
 - 450mm above electric hobs and cookers
 - 750mm above gas hobs and cookers, fryers
 - 760mm above wok burners, griddles, barbeques.
- maximum recommended clearance: 850mm

The minimum distance between the hob and the bottom of the extractor is essential for safety reasons and to prevent overheating of the extractor and its components.

Please also note that a 90° bend in flexible ducting will require 215mm minimum headroom to give a smooth radius with no kinking.

You are advised to install measures designed to reduce the incidence of cold draughts entering the property via ductwork.

- For extractors with internal or inline motors, an external duct termination with integral non-return flaps (e.g. a gravity shutter wall vent/louvre) is the minimum draught prevention measure you should install.
- For wall-mounted motors an inline backdraught shutter is recommended.

3. EXTRACTION PERFORMANCE

This type of extractor is designed to fit into a soffit, with only the underside visible when installed.

Because fumes spread out as they rise, try to position the extractor so it sits as far forward over the hob as is practicable in order to minimise fume escape.

The primary influence on the overall performance of the extractor is the design of the ducting which takes the exhaust air from the extractor to the outside. The duct route should be a prime consideration during the initial stages of the kitchen design. Westin do not recommend recirculating air back into the kitchen if it can be avoided.

Please note the following:

- **The extractor is provided with a spigot(s) suitable for connecting 150mm round ducting (or equivalent cross section). Ducting must not be reduced.**

Note: Failure to adequately fit the ducting stated above will void your written Guarantee under the Standard Guarantee conditions.

- The most efficient configuration is to duct straight through an outside wall, so try to position the cooker close to an outside wall when designing your kitchen.
- For maximum efficiency, ducting should be kept as short as possible and as straight as possible with a constant cross-sectional area being no less than that recommended by Westin. Bends in the duct will also degrade performance so the number of bends in a duct run should be kept to a minimum and be gradual and smooth to prevent turbulence. Avoid kinks in flexible ducting; pull flexible ducting taut over straight runs to ensure that the internal surface is as smooth as possible.
- If your duct route is straight but exceeds 7m in length, or exceeds 5m with three bends, then please consult with Westin as to the suitability of this hood for your application.
- Rigid 150mm round ducting or 220 x 90 flat channel ducting (available from *Westin*) will perform best. Semi-rigid round duct (not flexible foil or PVC) is a reasonable alternative and can be formed into bends as necessary.

Flexible ducting is economical but its use should be minimised because it gives the worst performance of all and should only be used for the initial connection between the hood and your fixed ductwork or for very short runs. Flexible duct must be pulled taut over straight runs to prevent significant losses in extraction efficiency.

- Try to maintain access to the duct route during installation. Blind fitting of ducting parts can lead to problems, such as unseen kinks or damage.
- If using rigid ducting, **the initial duct connection to the extractor spigot** should be made using semi-rigid round ducting. This will allow ducting to be connected to the extractor before inserting it into furniture, allows for easy removal and refit (if service is ever necessary) and gives tolerance for positioning errors between the extractor and any fixed ducting or holes.
- Ducting components and kits, are available from *Westin*.



4. INSTALLATION

The *Bloque Pro* range of built-in extractors are designed to slot into a cut-out/opening made in a horizontal soffit panel (usually the underside of kitchen furniture or inglenooks/ chimney arrangements).

General arrangement drawings can be found from page 6

4.1. Prepare Your Opening

Prepare an opening in the structure into which the unit will be fitted (see table below). Reinforce the opening as necessary and make suitable provisions for the screws that will hold the unit in place.

Unit Size (mm) (Width x Depth)	Cut-out Size (mm) (Width x Depth)
1200 x 445	1170 x 415
1500 x 445	1470 x 415

The appliance features fixing holes in the chassis that are used to fix the appliance in place within the soffit. These fixing holes are accessible from within the unit. Remove the grease filters to gain access to the fixing holes.

Prior to fitting the appliance, a timber structure will be required as shown below. The timber sections (or batons) should be located in order for a suitable wood screw to pass through the appliance fixing holes and securely bite into the timber structure without any give or wobble.

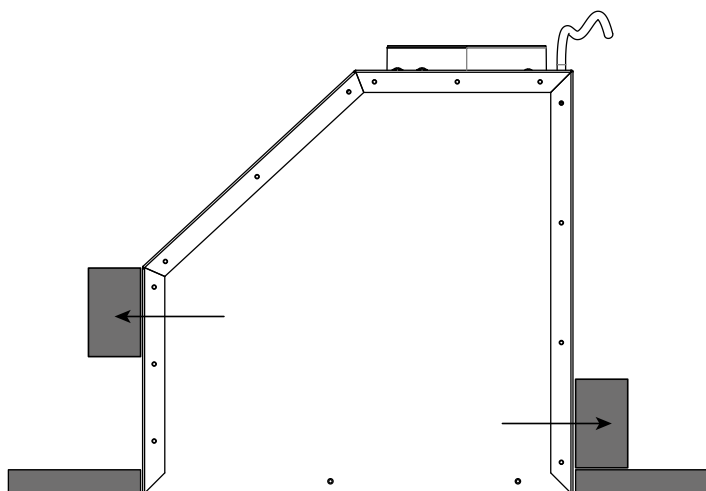

4.2. Ducting Requirements and Installation

Make holes, as necessary, in the furniture, walls, or ceiling to take 150mm round ducting (or an equivalent flat channel duct) from the exhaust spigot location to the outside.

The duct route length should be kept as short as possible with as few bends as possible (see Section 3).

Note: We recommend oversizing your duct holes by 25mm to allow for any cables that may need to run alongside the duct (such as remote motor or power cables) and to generally make the installation of your ducting easier.

You should try to install all ductwork before fitting the extractor, however, if this is not possible then all holes in walls or furniture must be made in advance of fitting the extractor to avoid any debris entering the appliance.

Regardless of the duct type being used for the majority of your duct run, the initial duct connection to the extractor spigot should be made using semi-rigid 150mm round ducting. You should therefore terminate your duct in the kitchen such that a length of semi rigid duct hangs down through the opening in your soffit. This is important because it will enable the ducting to be connected to the extractor exhaust spigot before it is inserted into the furniture and allows for easy removal and refit if service is ever necessary. It also gives a degree of tolerance for any misalignment between the extractor spigot and any fixed ductwork.

Moving the fan for a rear outlet position

In order to re-position the fan for a rear outlet position from the extractor: Expose the fan by removing the filters. Locate and remove the 4 fan retaining nuts and washers. Lower the fan. Remove the fixings retaining the blanking plate in the rear of the extractor and re-position the blanking plate in the top outlet position. Rotate the fan into the rear outlet orientation and fit to the rear of the extractor (where the blanking plate once was) and re-fit the washers and nuts. If fitted, ensure that the thin steel brackets remain connected to the fan and fan bracket.

General arrangement drawings can be found from page 6

If terminating on an outside wall a suitable weather louvre should be fitted. A variety of ducting components and complete kits are available from *Westin* to suit most installations.

For roof or chimney duct terminations please contact *Westin* or seek alternative specialist advice.

If you are fitting a wall-mounted external motor with semi-rigid or flexible ducting, then you must leave a short length (approx. 200mm) of ducting proud of the wall, to enable connection to the motor spigot, before pushing both back flush with the wall.

• Recirculating Models

Westin do not recommend recirculating air installations and they should be avoided wherever possible (see section 3).

If your extractor has been adapted for recirculation, (not the standard configuration) then adequate provision must be made for exhausted air to return into the kitchen after being expelled from the extractor exhaust spigot. Adequate provision means the air can travel back to the kitchen via means equivalent to that of 150mm round ducting. This can be achieved, for example, by ducting to a vent in the top of a cabinet (or elsewhere in the room) or by creating an opening into the room in the top of your furniture. Failure to allow the air back into the kitchen will render the extractor ineffective, may cause the unit to overheat and fail, and will invalidate your warranty.

4.3. Remote External Wall and Inline SEM Motors

If your extractor has been purchased to operate with a standard inline or external remote motor (SEM), then you will find a black plastic terminal box above the extractor, on a flying lead, containing electrical terminals for connection to the remote motor cable assembly. This box is referred to as the remote motor terminal box.

Each terminal inside the remote motor terminal box has one side connected to a coloured wire (which leads back to the hood control system). The remote motor cable assembly also has coloured wires and these are connected to the empty terminal. Such corresponding colours are opposite and connect to each other; i.e. red connects to red, blue to blue, and so on.

Not all terminals will be used as each remote motor type is configured differently.



Installation, Operating & Maintenance Instructions

An electrician (or Part P registered electrical installer) should undertake any work associated with the electrical installation of SEM remote motors.

Please refer to the Remote Motor Wiring Illustrations on Page 9 for detailed and motor specific wiring information

If you need to extend the remote motor cable then additional cable can be purchased from *Westin*. Alternatively, it may be extended using 7 core x 0.5mm flex. It is vital to ensure that any new cable is inserted such that the core colour integrity is maintained; i.e. a core that started as red must terminate as red, blue as blue, purple as purple, and so on.

Any remote motor should be installed in accordance with the installation instructions that accompany it. It must be installed in an easily accessible location for future maintenance. *Westin* are not responsible for providing the means of access (e.g. scaffolding or any alterations to the building and/or furniture necessary to make access possible) in the event of any maintenance requirement.

No separate power supply is required for SEM remote motors.

4.4. Electrical Installation

**ELECTRICAL HAZARD.
DISCONNECT ELECTRICAL SUPPLY BEFORE
PROCEEDING FURTHER**

The extractor is a stationary appliance supplied with an electrical supply flex and moulded 3 pin UK plug (3A) for connection to the electrical supply.

The appliance must be fed from a 230Vac single phase electrical supply. You may wish to terminate the electrical supply using a standard mains electrical socket positioned close to the extractors intended location.

Alternatively, you may terminate the electrical supply from a switched-fused spur. The spur should be located adjacent to the hood/cooker so that the supply can be disconnected from the hood using the switch. The means of disconnection from the supply must have a minimum contact separation of 3mm in all poles. A competent Part P registered electrical technician must perform the electrical installation.

The mains supply is connected as follows:

INCOMING SUPPLY CORD CONNECTIONS	
Core	Core Colour
Live	Brown
Neutral	Blue
Protective Earth	Green/Yellow

Make sure the switched-fused spur supplying the extractor is in the off position before connecting the appliance to the electrical supply.

4.5. Fixing the Extractor in Position

When planning and undertaking your installation, you must ensure the extractor can be removed without disturbing fixed ducting or electrical installations, should future servicing be required.

Please note the following prior to commencing fixing the extractor in position:

- Two people are required to install the unit.
- The unit will need supporting close to the opening when attaching the ducting and making electrical connections.
- As described in 4.2 (Ducting Requirements), ducting should have been installed so that a semi rigid or flexible portion hangs down through the soffit opening.
- Do not remove protective tape until after the installation.
- Remove the grease filters.

Screws for fixing the extractor into position are not provided. You must use suitable fixings capable of supporting 30kg per screw.

If you are screwing into timber, then you should use screws no smaller than 5mm (No 10) with a head diameter of 10mm or more and ensure that at least 35mm of thread is screwed into the timber and that the timber will not split when the screws are inserted.

The unit will need supporting close to the opening when attaching the ducting and making electrical connections – do not be tempted to install excessive ducting as this will impair performance.

As described earlier, a length of semi-rigid ducting protruding a short distance through the centre of the opening is sufficient for the final connection to the extractor spigot. This will allow the unit to be fixed into position with the duct connected and prevents excessive lengths of flexible ducting being pushed into the opening. This may lead to loss of efficiency. (see section 3).

- Support the extractor just below the prepared cut-out so that the spigot and electrical connections are accessible.
- Make sure that the electrical supply to the electrical supply spur is isolated (switched off) and connect the electrical supply cord of the extractor to the spur.
- Attach the ducting to the spigot using suitable clamps or straps (available from *Westin*). We do not recommend using duct tape as the only means of fixing - this should only be used to improve the seal in the joint.
- Push the extractor up into the cut-out, taking care not to crush or introduce excessive bends/kinks in the ducting and making sure that no wires are trapped or damaged in the process.

Note: If the duct or any wires are trapped, then you must lower the extractor and make corrections to the cut-out area as necessary before fixing the appliance in position.

- Secure the extractor in place using suitable fixings (not supplied) through the fixing holes within the extractor body.
- Now test the function of the unit as described in the operating instructions (SECTION 6).

If the lights or motor do not function correctly, then isolate the electrical supply and check all the electrical connections before contacting *Westin*.

If you experience any further difficulties, please call *Westin* for advice.



Installation, Operating & Maintenance Instructions

5. SPECIFICATIONS

All Models	
Supply voltage:	230V~ 50Hz
Recommended fuse size for electrical supply	3A
Lighting: LED (Per Lamp):	12V, 2.6W
Bloque Pro 1200mm	Lamps x 4
Bloque Pro 1500mm	Lamps x 5
Extractor Duct Spigot Diameter:	150mm
Total power:	See rating plate

Internal Motor Specifications	
Airflow, nominal in free air:	800 m ³ /hr
Power input:	275W
Duct Spigot diameter:	150mm

SEM1 EL Inline Duct Motor Specifications	
Airflow, nominal in free air:	800 m ³ /hr
Power input:	275W
Duct Spigot diameter:	150mm

SEM2 EL Wall Mounted Motor Specifications	
Airflow, nominal in free air:	900 m ³ /hr
Power input:	200W
Duct Spigot diameter:	150mm

SEM7 EL Wall Mounted Motor specifications	
Airflow, nominal in free air: 200mm Diameter Duct	1,700 m ³ /hr
Airflow, in free air via supplied 150mm reducer	1,500 m ³ /hr
Power input:	490W
Duct Spigot diameter:	200/150mm
<i>Note: The motor has a 200mm diameter spigot and is supplied with a reducer for connection to 150mm ducting.</i>	

SEM8 EL Inline Motor specifications	
Airflow, nominal in free air: 200mm Dia Duct	1,300 m ³ /hr
Airflow, in free air via supplied 150mm reducer	1,100 m ³ /hr
Power input:	250W
Duct Spigot diameter:	200/150mm
<i>Note: The motor has a 200mm diameter spigot and is supplied with a reducer for connection to 150mm ducting.</i>	

For detailed performance, specification and energy efficiency information please refer to the product fiche for your product

6. MAINTENANCE

Regular maintenance is essential to ensure good performance and long-life.

CAUTION.

To minimise the risk of fire, all instructions relating to cleaning the grease filters and removing grease deposits must be adhered to.

To maintain the immaculate appearance of the extractor, and to minimise fire risk, ensure that grease deposits on the extractor surfaces are kept to a minimum by regular cleaning.

To clean the stainless-steel surfaces of the extractor, use a soft cloth and a suitable cleaning agent, such as a specially produced stainless-steel cleaner, or washing up detergent and warm water.

Painted surfaces should be cleaned using a soft cloth, detergent and warm water.

Glass surfaces should be cleaned with a suitable glass cleaning agent.

- **Do not use bleach-based cleaning products or abrasive materials.**

Clean the grease filters in a dishwasher or by hand-washing in hot water and detergent every 2 months - sooner if the extractor is used extensively and filters become grease laden.

- Whilst you can expect years of service from mesh grease filters, they are considered a consumable item and may deteriorate over time and need replacement, particularly when cleaned in a dishwasher. For dishwasher users adhering to a 2-monthly cleaning interval, we recommend grease filter replacement every 5 years to maintain optimum performance, even if they show no visible signs of deterioration. For all users, filters should be replaced whenever they exhibit signs of physical wear.

Removing the Grease Filters

The clip-in grease filters have an integrated sprung latch mechanism. Release the latch by pulling the lever and remove the filter.

Filters are replaced by locating the tabs opposite the lever into corresponding slots in the extractor base and then pushing the filter into position with the latch held open. Once the filter is in position release the lever, allowing the latch to engage.

Lamp replacement

The long-life LED units are not designed for end user replacement. In the unlikely event of failure please call Westin.

Main Reset Switch

The Reset Switch is a red rectangular switch located inside the extractor. The Switch can be accessed by removing the Filter(s). Press the Reset Switch to unlatch 'out'. Press the Reset Switch again to relatch 'in'. The Switch must be in the latched 'in' position in order for the extractor to operate.

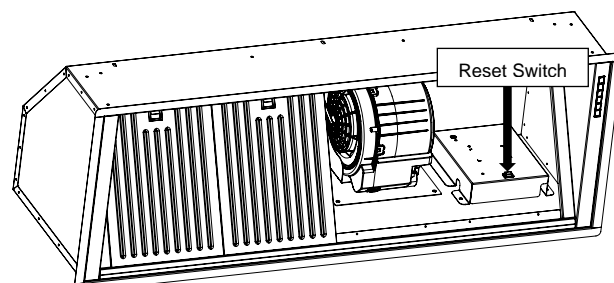



7. OPERATING INSTRUCTIONS

Radio Remote Controlled Models

- Switch on the power at the fused spur.
- Then Immediately turn on the remote control (⏻).
- Then immediately press and hold (☼) until the lights illuminate.

Should the extractor fail to respond to commands from the remote-control, please check that the power is 'on' and the internal appliance reset switch is in the 'ON' position (factory default). The reset switch is a latching red push-switch located in the chamber behind the door panel / filter.

If you experience interference problems, or the remote appears to be faulty from new, then a different radio transmission code may be required.

Refer to the instruction leaflet included with the remote control regarding transmission code changes before seeking assistance.

Pushbutton Models

Pushbutton Functions

(for models with pushbutton controls)

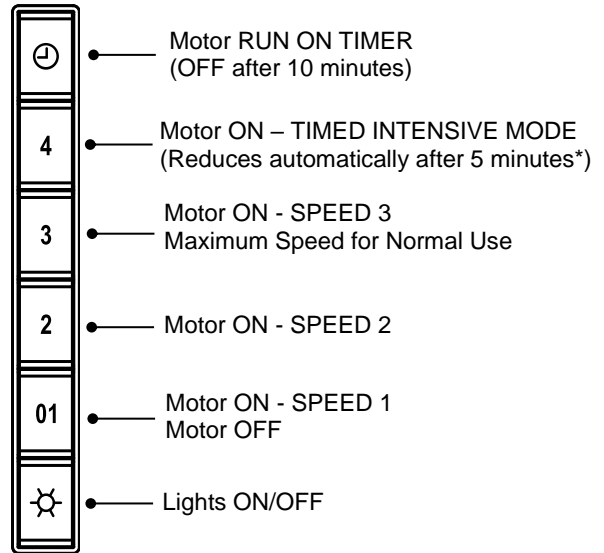

The extractor controller automatically switches off the appliance if there has been no operator action for 4 hours.

After 30 hours accumulated running GREASE FILTER CLEANING will be signalled by all 6 indicators flashing. Reset by pressing (⏻).

**Speed 4 reduces automatically to Speed 3 after 5 minutes

Light Dimming

To adjust the light intensity, press & hold (☼) until desired intensity is set.

Colour Changing

Ensure that the fan, lights & timer are off. Press and hold (⏻) until the lights illuminate. Then press and hold (☼) until the desired light colour is achieved. Press SPEED 1 button to confirm the desired light preference. (or + if using the remote control).

Remote Control Functions

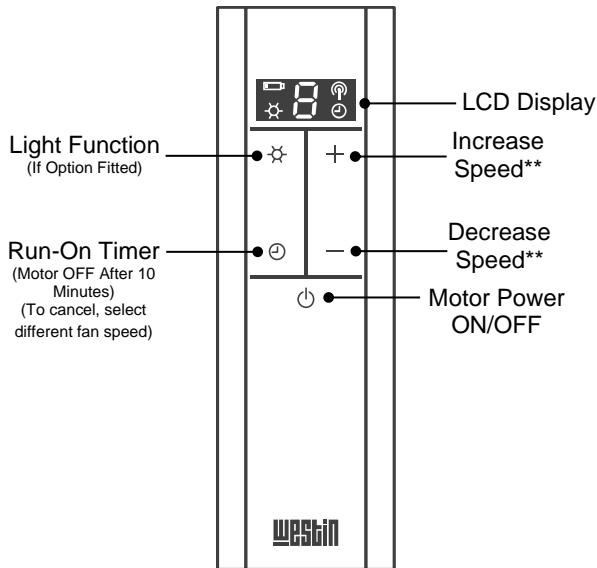

* The automatic speed reduction feature is required by EU Ecodesign and Energy Labelling Commission Legislation 65/2015 66/2014 in order to satisfy Directive 2009/125 EC

The extractor controller will automatically switch off the appliance if there has been no operator action for 4 hours.

Refer to the instruction leaflet included with the radio remote control console regarding pairing the device, transmission codes and factory reset procedures.

Other Control Systems

Because this is a custom-made product, an alternative control system may have been specified during the design phase.

Most commonly this alternative control system will be a continuously variable rotary fan speed controller plus light control mounted on the extractor (usually the baseplate). With most such control systems, you will find on/off switches for the fan and lights and a rotating knob to adjust the fan speed. Sometimes the switch and knob are combined into a single unit, like a domestic lighting dimmer switch, which is pressed for on/off function and turned for speed.

In some cases, the fan control may have been specified as a separate item that does not form part of the extractor (e.g. a wall mounted controller). Such controllers may have been supplied by the manufacturer or a third party and are not covered by this manual.

If you are unsure how to operate your unit then please call the manufacturer for assistance.

BLOQUE PRO Built-in Unit

Installation, Operating & Maintenance Instructions



8. GENERAL ARRANGEMENT DRAWINGS & ILLUSTRATIONS

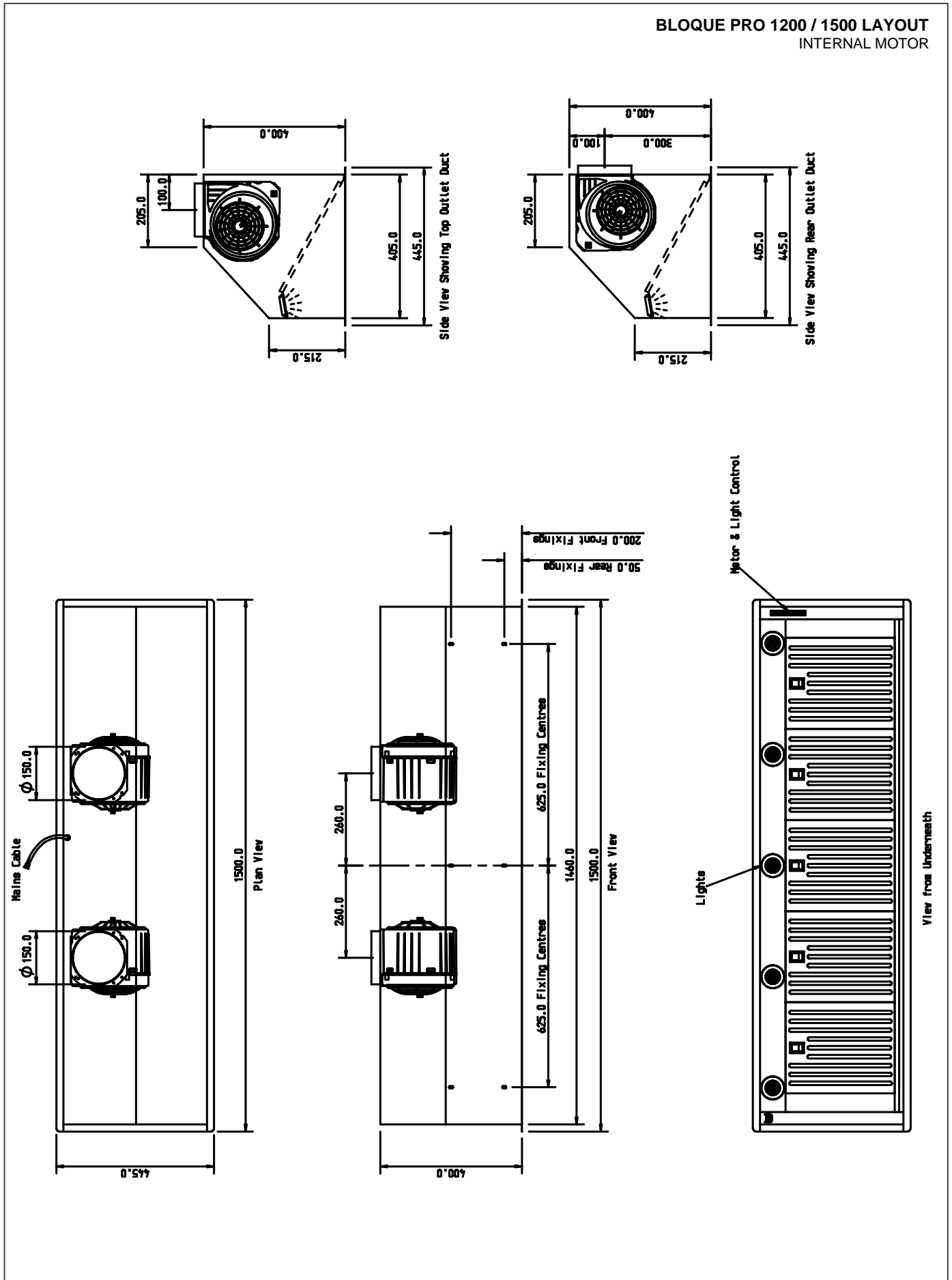

BLOQUE PRO Built-in Unit

Installation, Operating & Maintenance Instructions



BLOQUE PRO 1200 / 1500 EXPLODED VIEW
INTERNAL MOTOR

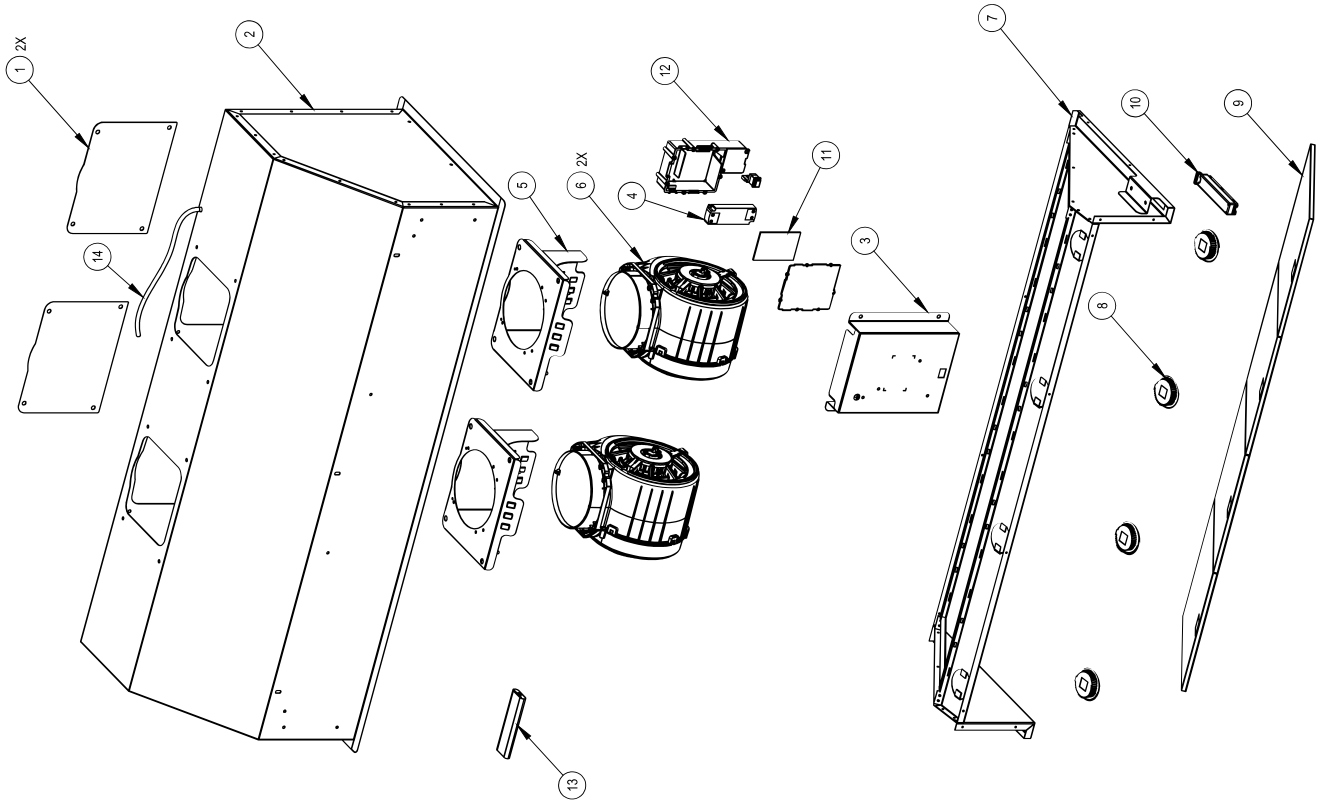

NO.	Part Name	Part Number	Notes & Special Ordering Instructions
1	Blanking Plate	Made to Order	
2	Extractor Body	Made to Order	Slate Hood Width
3	Control Box Enclosure	Made to Order	
4	Lighting Driver	W1094	
5	Motor Bracket	Made to Order	
6	Motor	W1437	
7	Extractor Base Plate	Made to Order	Slate Hood Width
8	LED Lamps	W1729	Refer to Table Below for Quantity
9	Grease Filter	W1371	Refer to Table Below for Quantity
10	Pushbutton Module	W1741	
11	Circuit Board	*W1836	
12	Circuit Board Housing	*W0419- *W0421- *W0422	
13	Remote Control	W1798	
14	Power Cable	UK - W1490 EU - W1490	
	Internal Motor Assembly	W1790	*Parts Included with Assembly

PRODUCT WIDTH (mm)	LIGHT QUANTITY	FILTER QUANTITY
1200	4	4
1500	5	5



BLOQUE PRO 1200 / 1500 INSTALLATION
INTERNAL MOTOR

Typical Installation with batons.
PLAN VIEW

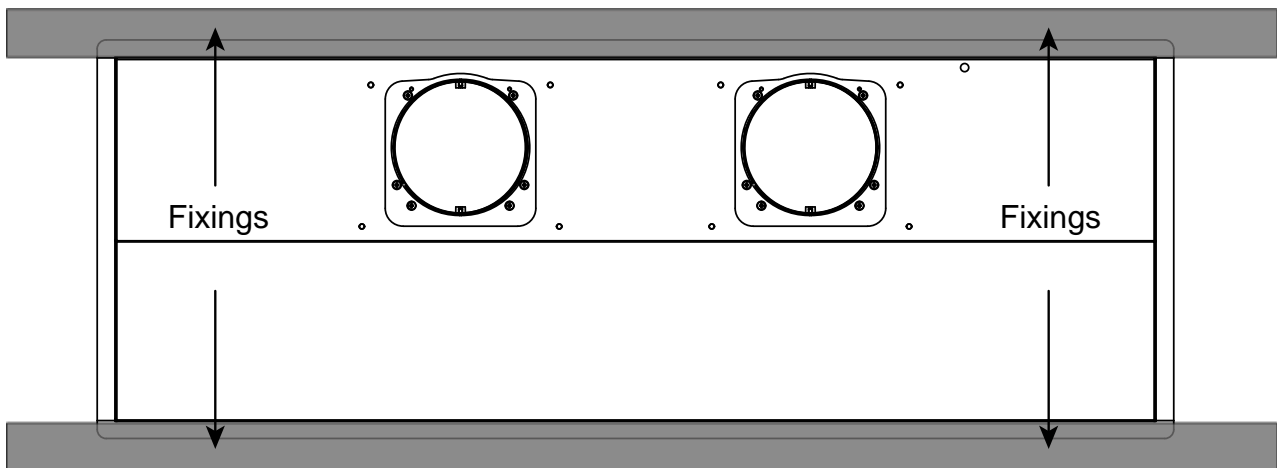

Unit placed within typical cut-out detail.
SIDE VIEW

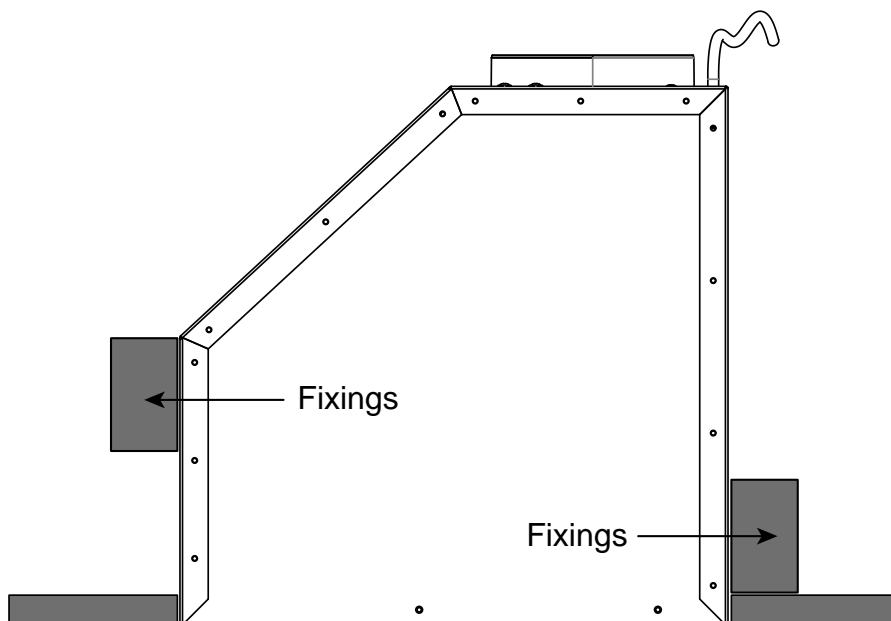



Installation, Operating & Maintenance Instructions

SEM-EL REMOTE MOTOR WIRING ILLUSTRATIONS for Energy Labelling Directive Compliant Motors SEM1, 2, 7 and 8

The wiring illustrations below apply to SEM EL Motors only.

The below diagram shows a typical SEM EL wiring schematic. the appliance is supplied with an external terminal box that requires connecting to the external motor.

In order to access the electrical terminals, remove the fixing screws from the external terminal box lid. Refer to fig. 2 & 3 for details of how to wire the SEM 1/2 or SEM 7/8 correctly.

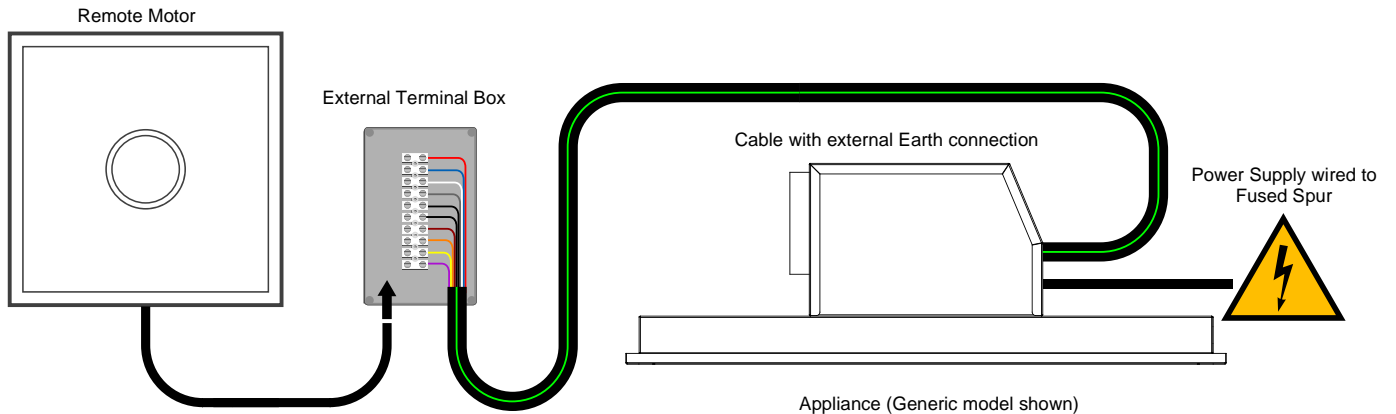

Fig. 1 Typical System

Fig. 2 Terminal Colour Positions

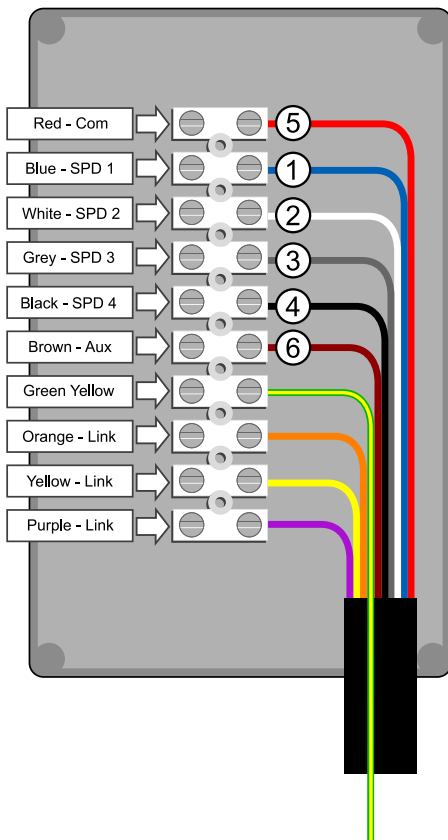

Fig. 3 SEM 1 / SEM 2 Electrical Connections

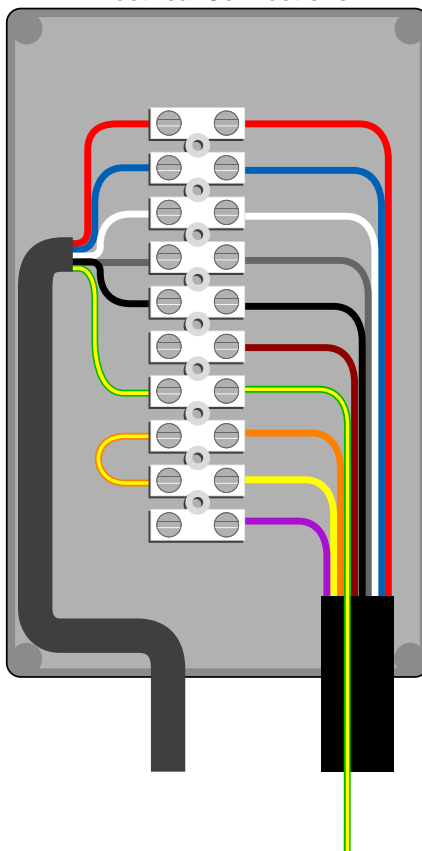
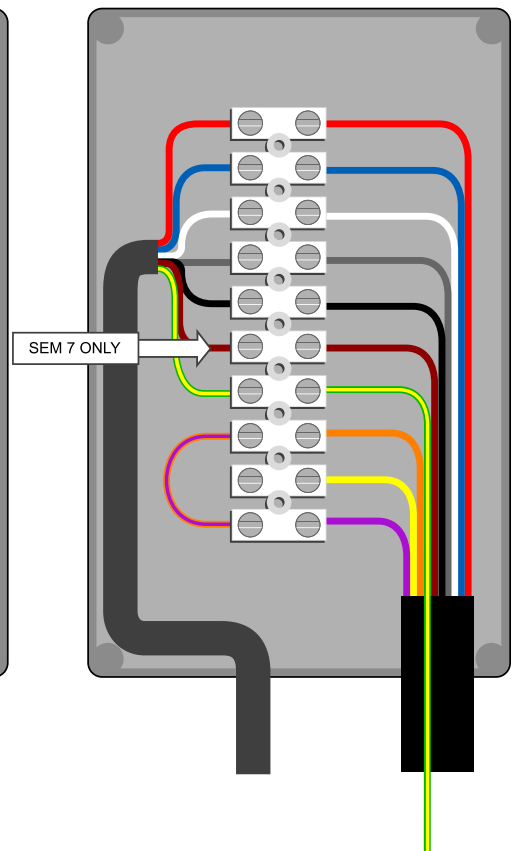

Fig. 4 SEM 7 / SEM 8 Electrical Connections



Note:
CHECK: COLOUR SEQUENCE MAY VARY
 Link terminals determine intensive speed run times, which are motor type dependent.
 Aux terminal powers auxiliary PCB in some motors.

Remote Motor Cable Assembly
 Orange/Yellow link wire is included

Remote Motor Cable Assembly
 (Orange/Purple link wire is included)

BLOQUE PRO Built-in Unit

Installation, Operating & Maintenance Instructions



STANDARD GUARANTEE CONDITIONS

Westin Ltd undertakes that if within 24 months of the date of delivery this product or any part thereof is proved to be defective by reason only of the faulty workmanship or materials, the company will, at our option, repair or replace the same FREE OF ANY CHARGE for labour, materials or carriage on condition that:

1. The product has been correctly installed and used only on the electrical supply stated on the rating plate.
2. The product has been used for normal domestic purpose only, and in accordance with the manufacturer's operating and maintenance instructions.
3. The product has not been serviced, maintained, repaired, taken apart or tampered with by any person not authorised by us.

EXCLUSIONS

This Guarantee does not cover:

- Damage or calls resulting from incorrect installation, transportation, improper use or neglect, the replacement of any light bulbs or removable parts of glass or plastic.
- Costs incurred for calls to put right appliances improperly installed or calls to appliances outside the United Kingdom.
- Normal wear and tear.
- Products deemed to be in use within a commercial environment.
- Grease filter mesh.
- Bulbs and LEDs.
- Consumables.
- Damage caused to the body by usage of detergent sprayer or other contaminants.
- Damage or corrosion of the LED parts, glass parts and stainless-steel parts.
- Damage caused by foreign objects or accident.
- Any products taken apart or serviced by unauthorised individuals or service engineers or replaced with other manufacturer's components.
- Product not installed with the correct size ducting as stated in the manual.

This Guarantee is in addition to your statutory and legal rights.

Please see our website www.westin.co.uk for details of our Conditions of Sale and to register your guarantee.